

Doc DM50

Wiring Diagram for DM Electric Valves *applicable to* Premium and Standard Valves

Single Switch Operation - 4 Pin to 4 Pin	Page 2
Dual Switch Operation - 4 Pin to 4 Pin	Page 3
Single Switch Operation - 4 Pin to 2 x 2 Pin	Page 4
Dual Switch Operation - 4 Pin to 2 x 2 Pin	Page 5



Wiring Diagram for Premium Electric Valves - Single Switch Operation - 4 Pin to 4 Pin

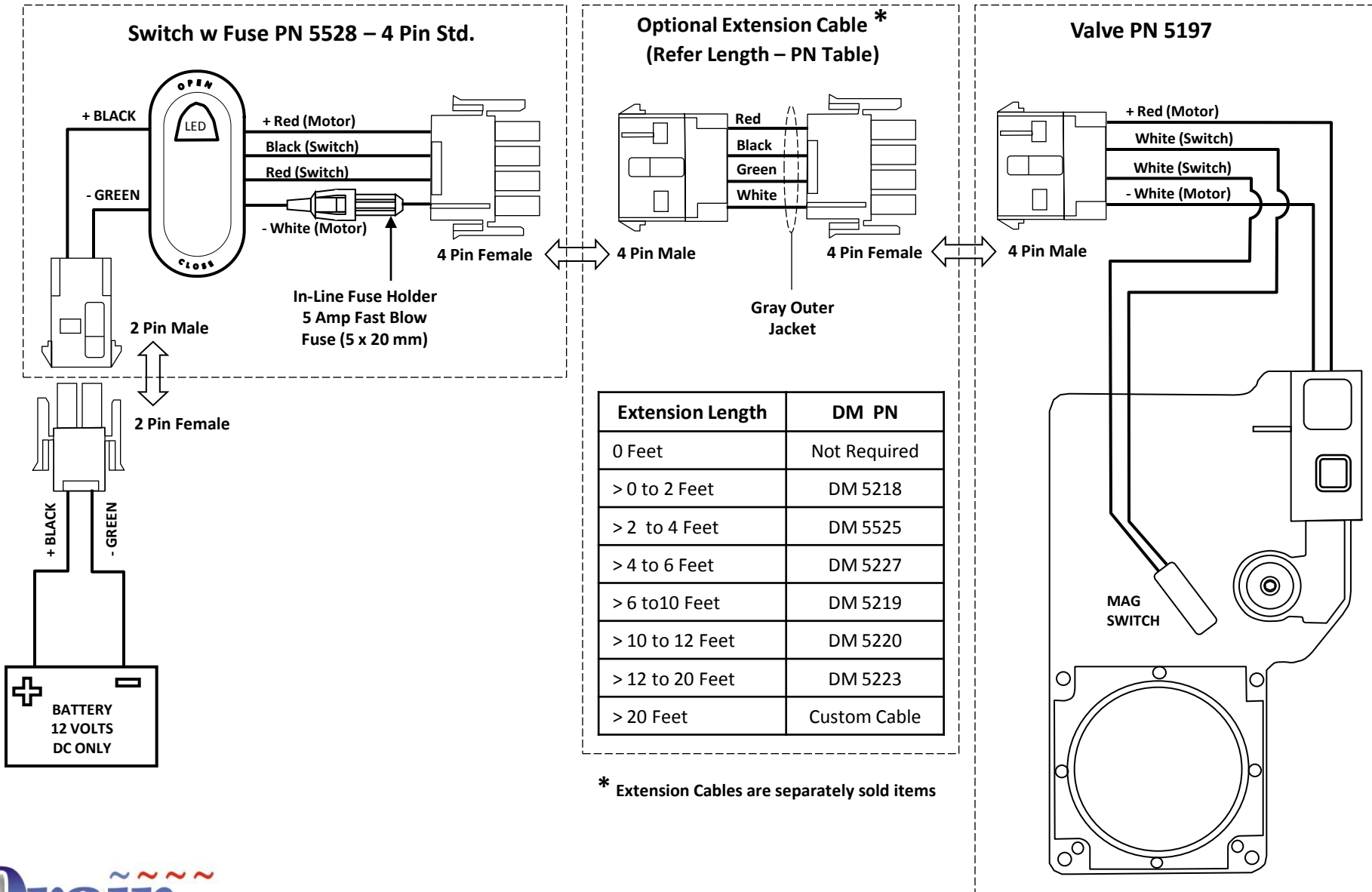

Wiring Diagram for Premium Electric Valves - Dual Switch Operation - 4 Pin to 4 Pin with 'Wye' Dual Port Harness

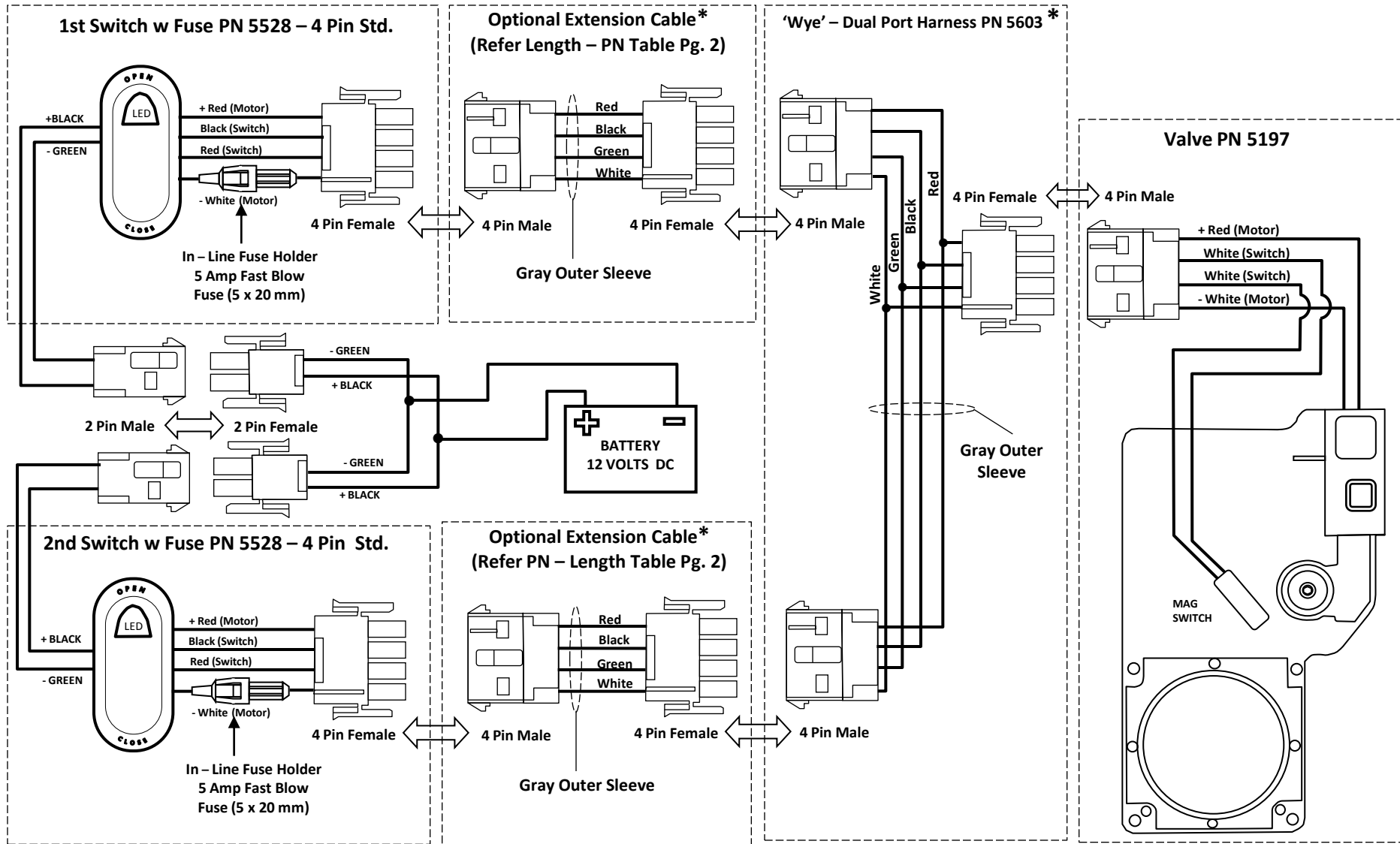

* 2nd Switch, 'Wye' Dual Port Harness and Extension Cables are separately sold items



Wiring Diagram for Premium Electric Valves - Single Switch Operation – 4 Pin to 2 x 2 Pin

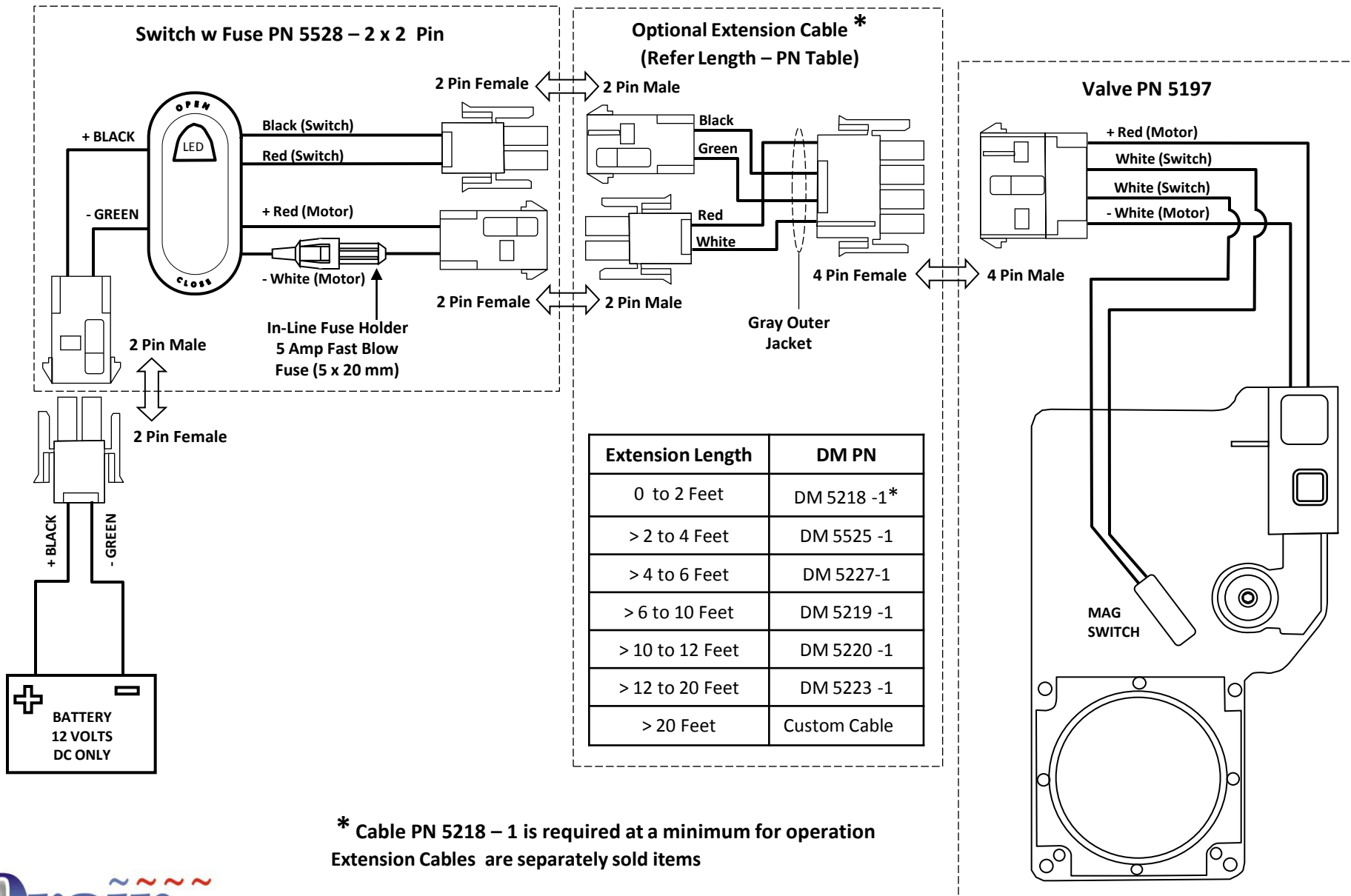

Wiring Diagram for Premium Electric Valves - Dual Switch Operation - 4 Pin to 2 x 2 Pin with 'Wye' Dual Port Harness

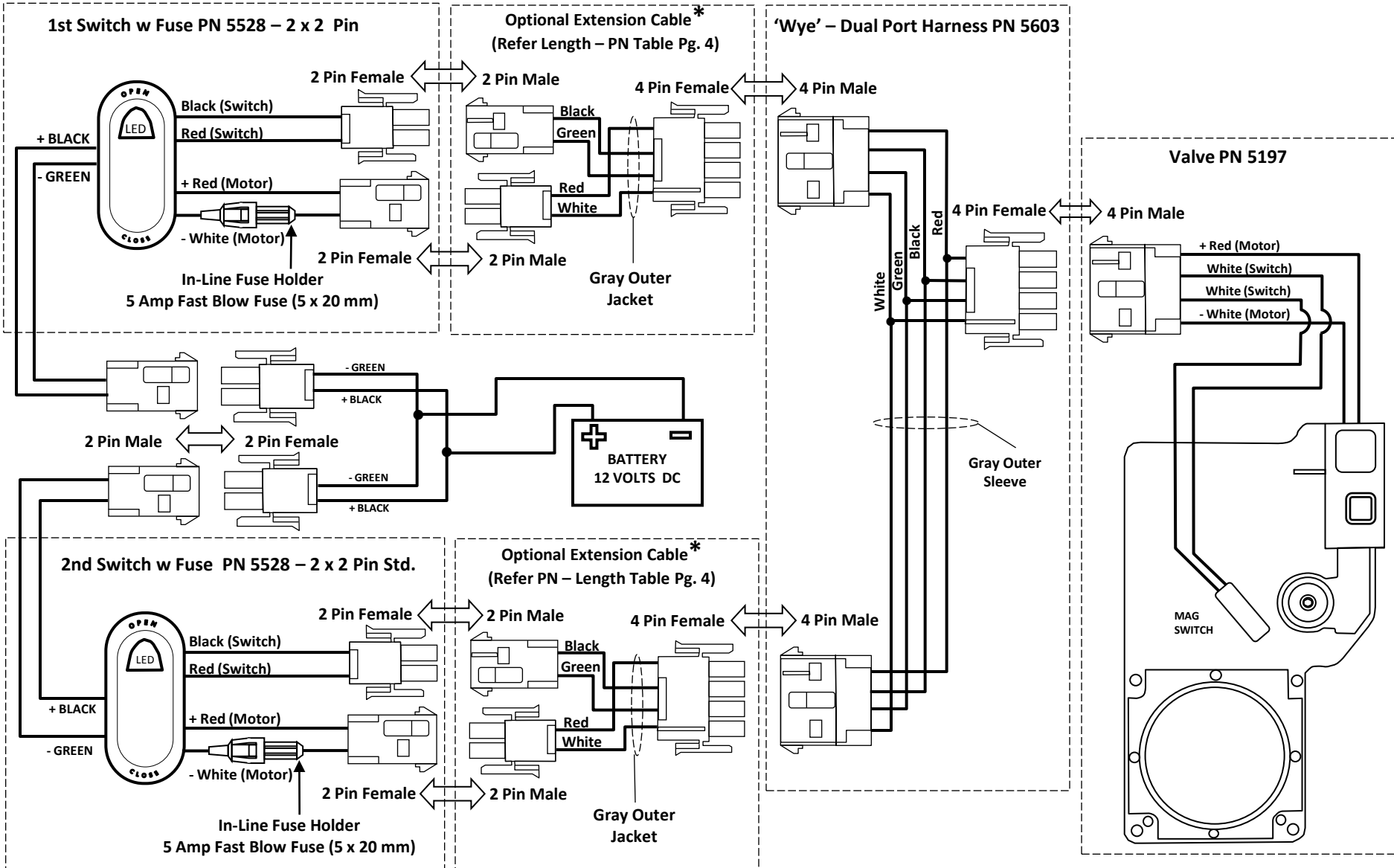

* PN 5218 - 1 is required at a minimum for operation. Extension Cables are separately sold items



Questions? Call 1 877 787 8833

10-SEP-2018

DM50-6

Pg 5/5