

# **TORKLIFT** **INTERNATIONAL**

**OVER 35 YEARS OF INNOVATION, QUALITY, SAFETY.**  
**IMPORTANT OWNER-OPERATOR INSTALLATION INSTRUCTIONS**

**A8001,A8101**

**Glow Step Revolution (GSR) Add-A-Step kit**

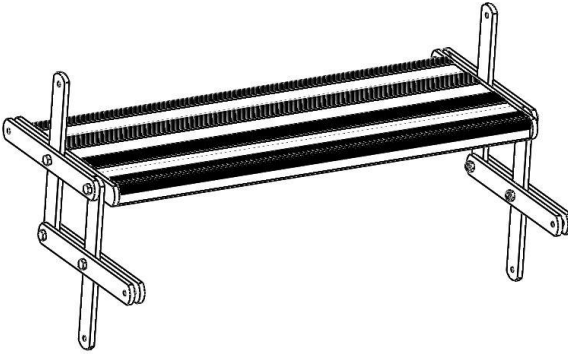









Version 1 BY: CW 9/18/15

**TECH SUPPORT (800) 246-8132**

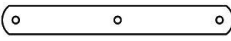
**AFTER INSTALL, PLEASE GIVE  
THIS BOOKLET TO YOUR CUSTOMER**

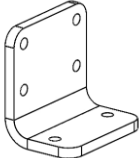
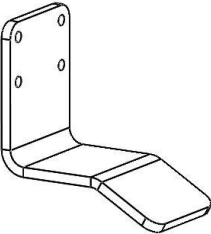
## Parts Inventory

Item Image	Item Description	Quantity
	1/4"-20 x 1-1/16" SS Hex Bolt	12
	1/4"-20 Thin SS Nylock Nut	20
	1/4" SS Thin Bushing Washers	24
	1/4"-20 x 1" SS Hex Bolt	8
	1/4"-20 SS SAE Washers	16
	3 Hole Link	10
	8" Welded Step Extrusion A8001 – 22" Long Extrusion A8101 – 20" Long Extrusion	1
	Upper Shelf Brackets	2
	Lower Shelf Brackets (Including Pre-Installed Slick Strips)	2
	7/32 Hex L Key	1

## Step 0: - Skip if adding onto a 3, 4, or 5 step

If you are converting 2-Step GSR into a 3-Step, remove the 1/4"-20 x 3-1/4" SS Phillips Machine Screw and associated nylon spacers from both sides of the GSR as shown in **Figure 0.1**. Replace them with a 1/4"-20 x 1-1/16" SS Hex Bolt. The removed hardware will be used in Step 1.

*Note: It is helpful to use a small screw driver to push the machine screw out. The screwdriver or punch going through the center of the thin washers between the 3 hole links will keep them from dropping out.*

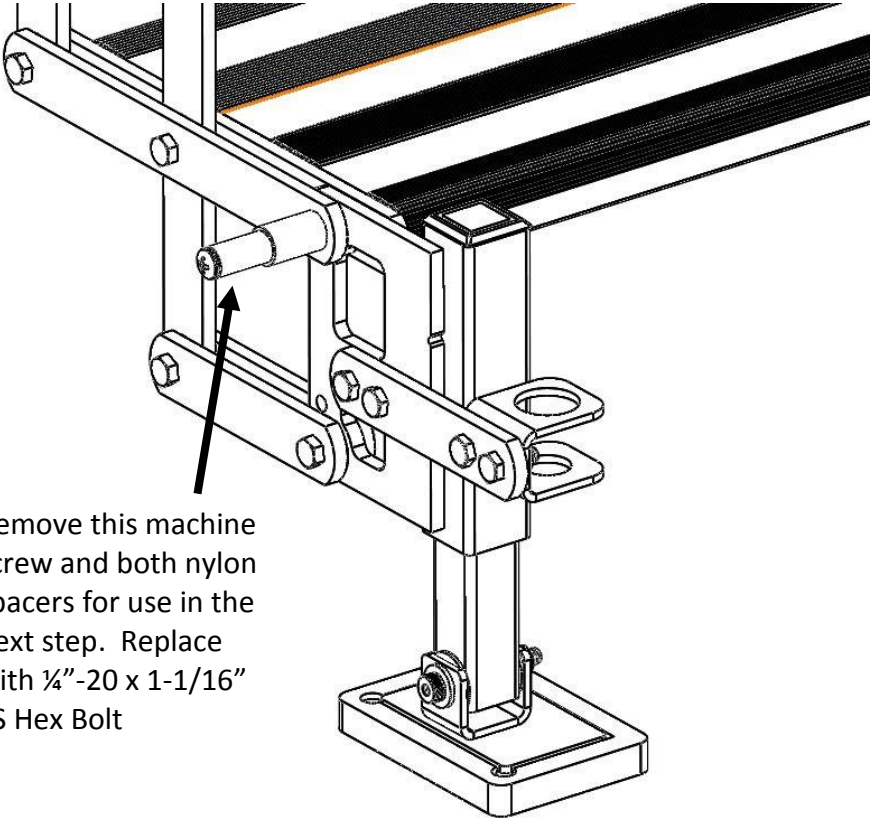

Remove this machine screw and both nylon spacers for use in the next step. Replace with 1/4"-20 x 1-1/16" SS Hex Bolt

**Figure 0.1**

# Step 1:

Assemble the **8" Welded Step Extrusion** and **3 Hole Links** as shown in **Figure 1.1**. When tightening the bolts, leave them loose enough that the links can be rotated with a low to medium amount of resistance. This can be adjusted to preference once installation is complete.

*(If you are converting a 2-Step GSR into a 3-Step GSR, use the 1/4"-20 x 2-1/4" SS Phillips Machine Screw and nylon spacers removed in Step 0 in place of bolt A)*

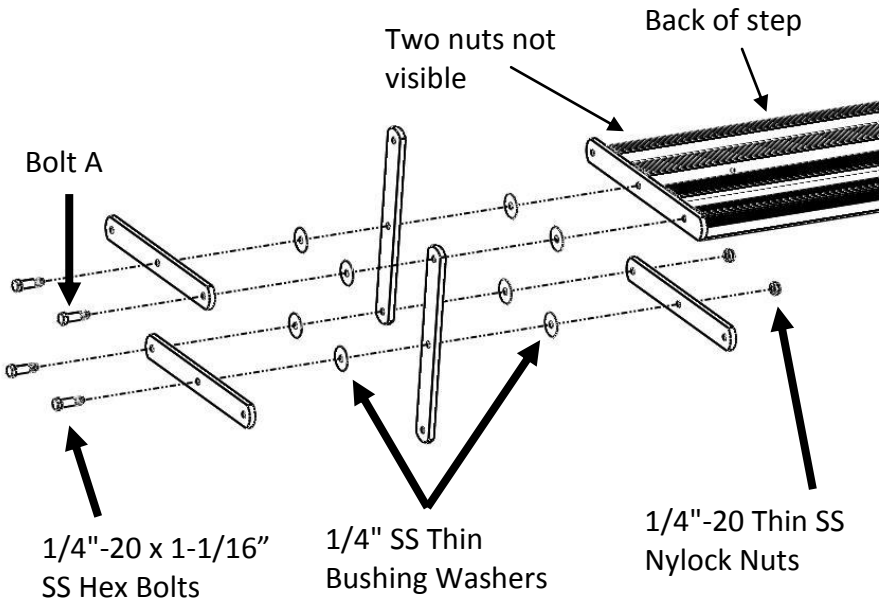

**Figure 1.1**

# Step 2:

Repeat the process for the opposite side of the **8" Welded Step Extrusion**. When complete, the Add-A-Step Assembly should appear as shown in **Figure 2.1**

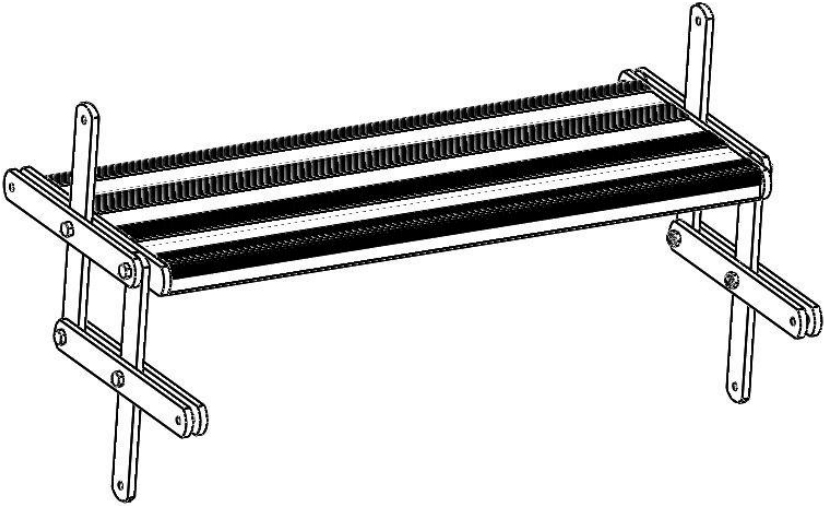

**Figure 2.1**

## Step 3:

Remove the hardware attaching the glow step assembly to the pivot arms as shown in figure 3.1 using the included **7/32 Hex L Key**. Save this hardware. It will be used later to reattach the steps.

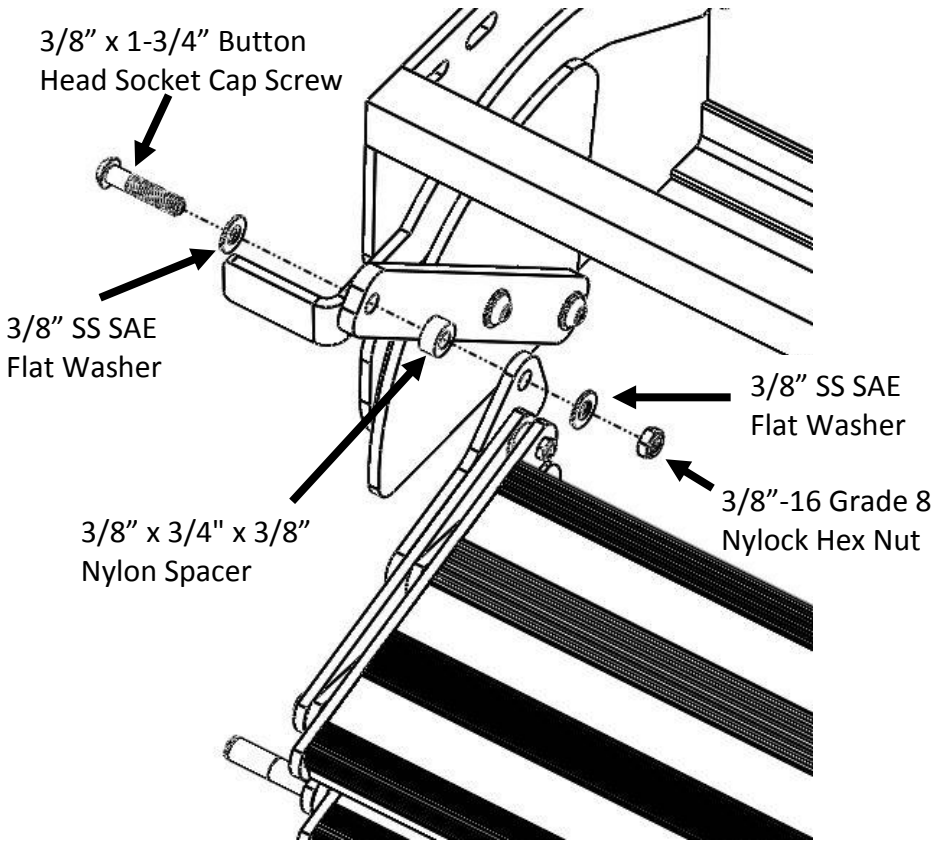

**Figure 3.1**

## Step 4:

Disconnect the lower step from your Glow Step Revolution by removing the **1/4"-20-1-1/6" SS Hex Bolts** as indicated in **Figure 3.1**. Save the hardware as it will be used for reassembly. Be sure to keep track of the **1/4" SS Thin Bushing Washers**, which are located between the **3 Hole Links**.

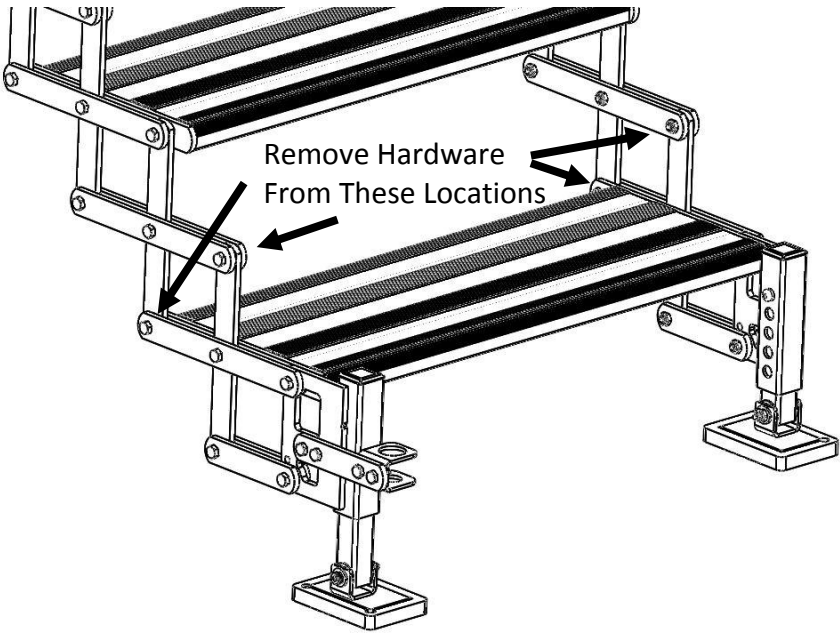

Y

# Step 5:

Attach the Lower Step Assembly to the bottom of the Add-A-Step Assembly, and the Upper Step Assembly to the top of the Add-A-Step Assembly as shown in **Figures 5.1 and 5.2**. You may find it easier to set the assembly on its side. This will help to keep the **1/4" SS Thin Bushing Washers** in place while installing the **1/4"-20 x 1-1/16" SS Hex Bolts**. A small screw driver will also be useful for aligning the Bushing Washers and flat bar links.

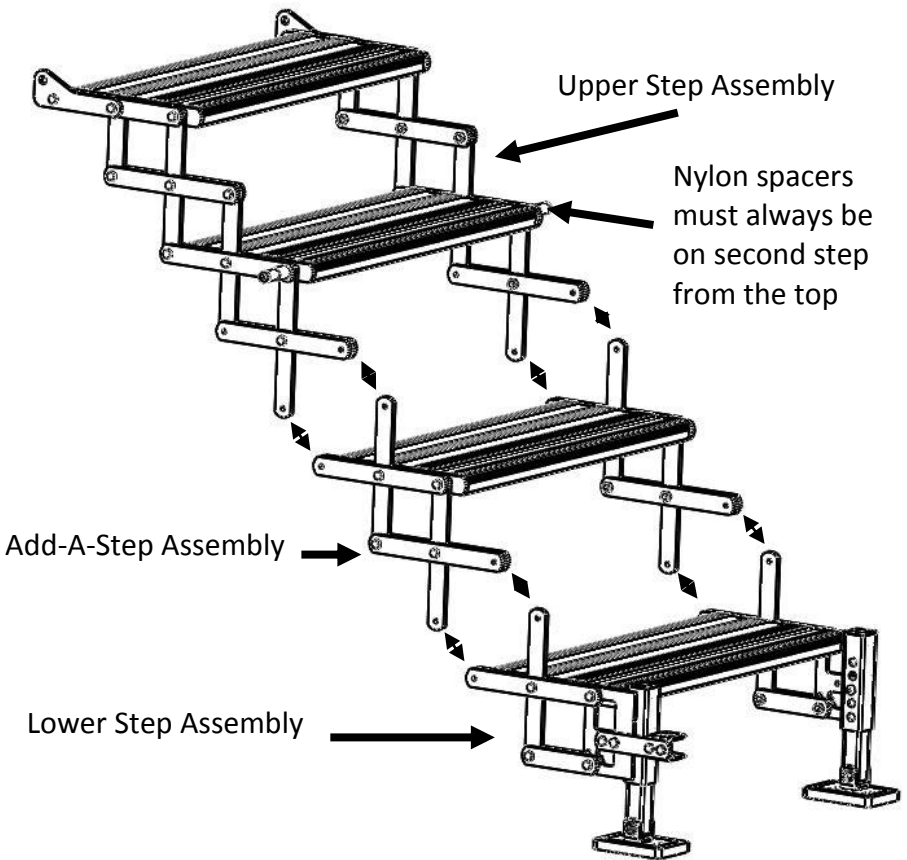

**Figure 5.1**



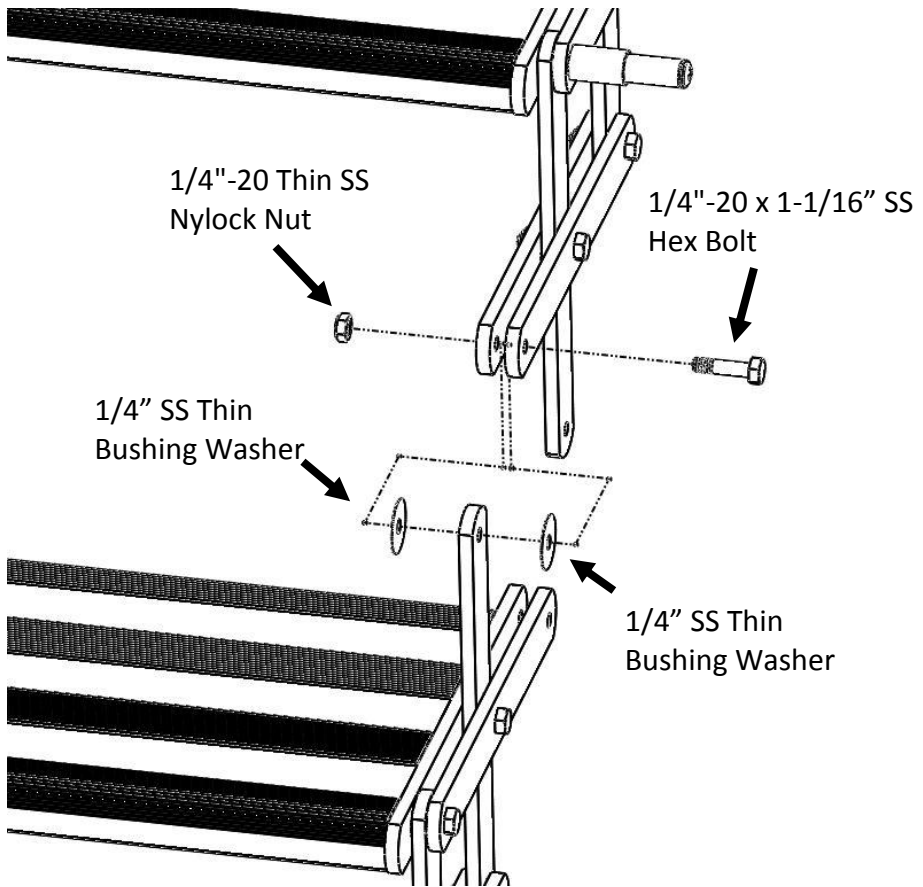

**Figure 5.2** Fasten all joints as shown.

## Step 6:

If after adding the Add-A-Step to your GSR Step Assembly, you have five or six steps, you will need to change the position of the step support shelves on the main GSR Mounting Bracket. Remove the Shelf Support brackets from your GSR, and mount them as shown in **Figure 6.2** for a 5-step, or **Figure 6.3** for a 6-step.

If you had a 3-Step GSR, and you now have a 4-Step GSR, you will be installing the **Upper Shelf Brackets** and **Lower Shelf Brackets** supplied with the Add-A-Step kit. See **Figure 6.1**.

*Note: There are two shelf support brackets per GSR. Both will need to be configured as shown.*

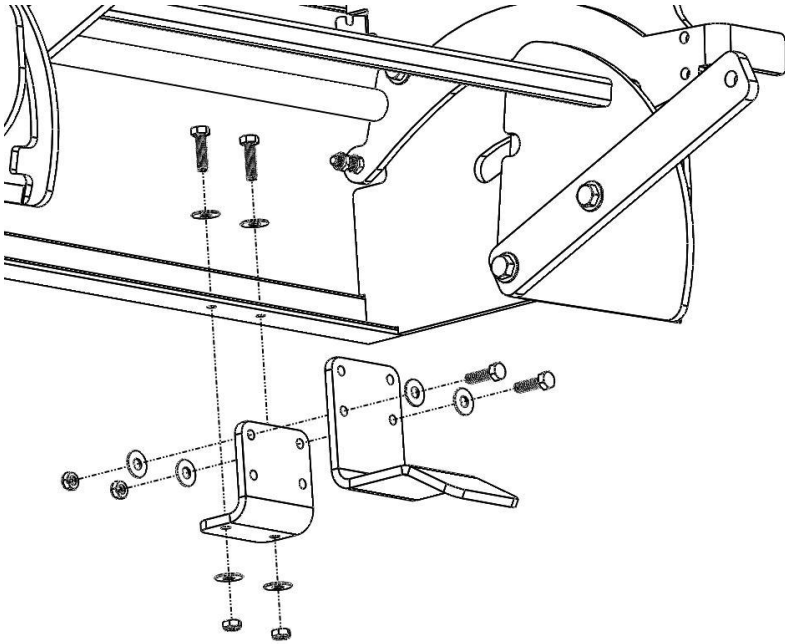

**Figure 6.1** 4-Step Shelf Bracket Installation

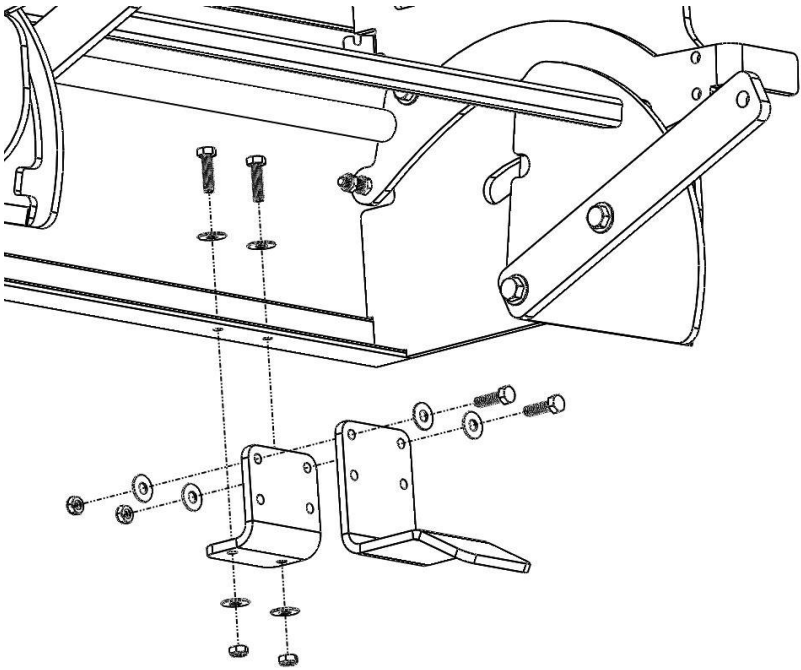

**Figure 6.2** 5-Step Shelf Bracket Installation

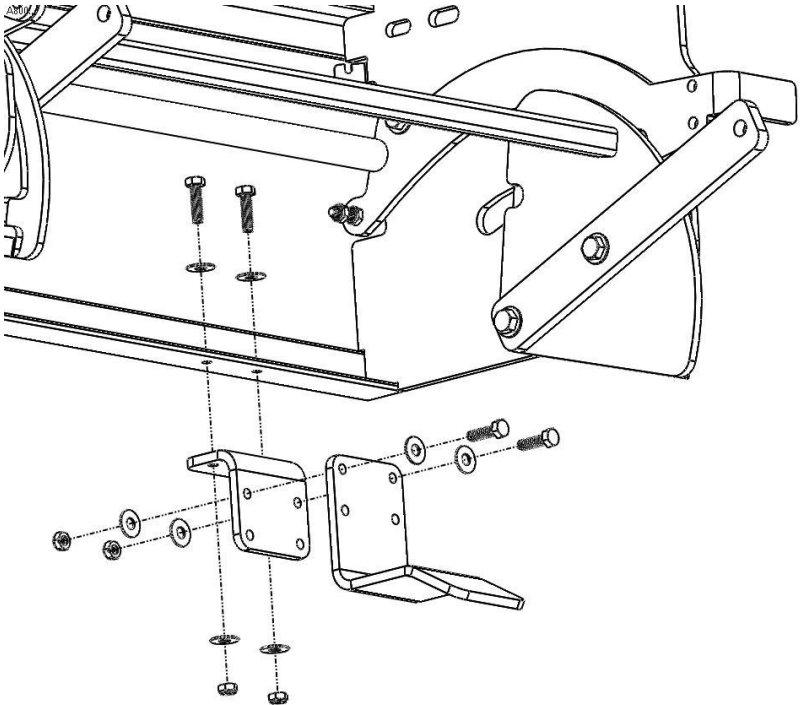

**Figure 6.3** 6-Step Shelf Bracket Installation

## Step 7:

Reattach the Glow Step Assembly to the GSR Arms as shown in figure 3.1.

Check the operation of the GSR by collapsing the steps and storing them. Pull the steps back out and repeat the process several times.

If the steps are too loose, the 1/4"-20 x 1-1/16" SS Hex Bolts in the side of the Step Assembly can be slightly tightened. If the steps are difficult to collapse, the 1/4"-20 x 1-1/16" SS Hex Bolts can be loosened. A small adjustment makes a significant difference. Typically 1/8 of a turn or less is enough to be noticeable.

Once Adjusted, your installation is complete, and your steps are ready for service.

# **Torklift International Limited Lifetime Warranty Information**

322 Railroad Ave North, Kent, WA 98032

Torklift will require proof of purchase to register, with pictures of any defective product before issuing a replacement. Torklift will not register any product without proof of purchase, which can be faxed, scanned, emailed, or mailed to the information provided below. Torklift warrants its hitches, custom hitch receivers, frame mounted tie downs, turnbuckles, and accessories (excluding wire harnesses which carry a 90 day warranty) from date of purchase against defects in material and workmanship under normal use and service for the ownership life of the original consumer purchaser. All plastic, rubber, and/ or electrical components maintain a warranty of up to one year from the date of the purchase. **ALL COMMERCIAL APPLICATIONS ARE WARRANTED FOR A PERIOD OF 90 DAYS FROM THE DATE OF INSTALLATION/SERVICE.** Torklift will replace **FREE OF CHARGE** any part which proves defective in material or workmanship when presented to Torklift, **TRANSPORTATION CHARGES PREPAID** by purchaser, at the address above. **THIS WARRANTY IS LIMITED TO DEFECTIVE PARTS REPLACEMENT ONLY. LABOR CHARGES AND/OR DAMAGE INCURRED IN INSTALLATION OR REPLACEMENT, AS WELL AS INCIDENTAL AND CONSEQUENTIAL DAMAGES CONNECTED THEREWITH ARE EXCLUDED.** This warranty does not include the finish or paint on our products. Rusting, cracking or peeling of the finish is also excluded. Some states do not allow the exclusion or limitation of incidental or consequential damages, so the above limitation or exclusion may not apply to you. Any damage to Torklift products as a result of misuse, abuse, neglect, accident, improper installation or any use violative of instructions furnished by Torklift or **WHEN USED IN ANY COMMERCIAL APPLICATION WILL VOID THE WARRANTY.** This warranty gives you specific legal rights, and you may also have rights which vary from state to state. With warranty service, you may be able to go to a small claims court, a state court or a federal district court.

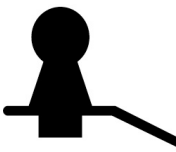

# TORKLIFT™

## INTERNATIONAL

322 Railroad Ave North, Kent, WA 98032

Phone (800) 246-8132 Fax (253) 854-8003

Or visit our website: [www.TorkLift.com](http://www.TorkLift.com)

Dear Valued Customer,

Thank you for making TorkLift your choice for truck, camper packages and accessories for your vehicle. By choosing TorkLift products, you have chosen a company that has been serving the RV industry for nearly 40 years and whose name has become synonymous with strength, quality and advanced design and installation.

Please take a few moments of your time to complete the Product Registration Warranty Card on the next page. When registering your newly purchased TorkLift products, you can be assured that your contact information is secure and that you and your product are getting the attention and respect that you deserve.

Thank you again for choosing TorkLift quality products.

**Register for your lifetime warranty and receive a free  
Torklift International gift.**

To Fax: Send copies of the questionnaire, warranty card and receipt to  
253-854-8003

To E-mail: Send copies of the questionnaire, warranty card and receipt to  
[warranty@torklift.com](mailto:warranty@torklift.com)

To Mail: Send to Torklift International 322 Railroad Ave North, Kent, WA 98032

**OFFICIAL WARRANTY REGISTRATION CARD**



**322 Railroad Ave North, Kent, WA 98032**

PLEASE FILL OUT THIS FORM COMPLETELY AND RETURN TO TORKLIFT WITHIN 30 DAYS OF PURCHASE ACCOMPANIED BY A COPY OF YOUR ORIGINAL RECEIPT

**1. PART(S) PURCHASED**

TODAY'S DATE: \_\_\_\_\_

PART #: \_\_\_\_\_ PART #: \_\_\_\_\_  
PART #: \_\_\_\_\_ PART #: \_\_\_\_\_  
PART #: \_\_\_\_\_ PART #: \_\_\_\_\_

**2. PURCHASER INFORMATION**

NAME: \_\_\_\_\_  
ADDRESS: \_\_\_\_\_

CITY: \_\_\_\_\_ STATE: \_\_\_\_\_ ZIP / POSTAL CODE: \_\_\_\_\_  
PHONE: (\_\_\_\_) \_\_\_\_\_ - \_\_\_\_\_ EMAIL: \_\_\_\_\_

**3. TRUCK INFORMATION**

YEAR: \_\_\_\_\_ MAKE: \_\_\_\_\_  
MODEL: \_\_\_\_\_ BED LENGTH: \_\_\_\_\_

**4. CAMPER INFORMATION**

YEAR: \_\_\_\_\_ MAKE: \_\_\_\_\_ MODEL: \_\_\_\_\_

**5. DEALER INFORMATION**

PURCHASED FROM: \_\_\_\_\_  
ADDRESS: \_\_\_\_\_

CITY: \_\_\_\_\_ STATE: \_\_\_\_\_ ZIP / POSTAL: \_\_\_\_\_  
INSTALLED BY: \_\_\_\_\_ OWNER ABOVE DEALER ANOTHER DEALER

IF ANOTHER DEALER, WHO: \_\_\_\_\_