

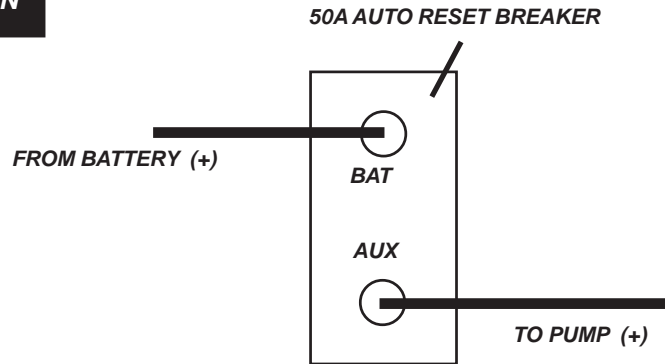

UPGRADING CIRCUIT BREAKERS FOR LCI HYDRAULIC PUMPS

ORIGINAL CONFIGURATION



NEW CONFIGURATION

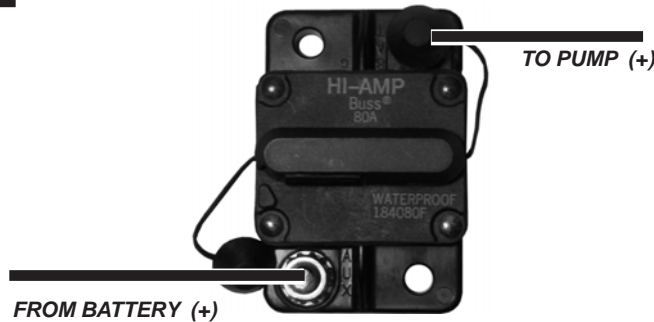

INDICATIONS

Due to high amp draws on hydraulic slideout systems, it may be necessary to upgrade the circuit breaker. During slideout operation, the higher amperage requirements on the hydraulic pump unit may cause the system to draw the voltage down. This voltage drop increases the amp draw and forces the 50A Auto Reset Breaker to trip and shut the system down. If the circuit breaker continues to trip, upgrading the 50A breaker to a breaker with a higher amperage rating will solve the issue without harm to the system. Wiring and breaker sizes are to be supplied by the RV Manufacturer. This applies to systems with and without individual room controls.

ENHANCEMENT CONDITIONS

- Operating in extreme cold temperatures
- Adding protective slideout awnings
- Operating with a low battery
- Carrying heavy items in slideout storage area
- Operating the slideout with all lights on in the trailer.

BE SURE TO TEST BATTERY VOLTAGE AND AMPERAGE PRIOR TO CALLING FOR SERVICE.

RV MANUFACTURER WILL SUPPLY THE MATERIAL INFORMATION FOR THE REPLACEMENT COMPONENTS