

# POWER TRIP 101

Hookup pedestals in campgrounds offering 50-amp service may give users more than they bargained for when wired incorrectly; pay attention because class is in session

It's common to find 50-amp electrical service in motorhomes these days, a requirement that's needed to power the expanding use of convenience appliances and energy-thirsty accessories. Most owners unknowingly feel pretty confident that if they plug into 50-amp service, they can run all their systems without restrictions. But that's not always the case, and what you see is not necessarily what you get. Understanding the complexities and limitations — yes, limitations — of 50-amp service will help prevent overloading and eliminate disappointments when it comes to taking advantage of fully equipped motorhomes.

OK, bear with us for a minute. Even though the receptacle found in your motorhome is rated at 120 volts AC, the 50-amp shorepower is actually a 120/240-volt AC, four-wire service (Figure 1). The acronym AC stands for "Alternating Current," which means the voltage is constantly changing from 0 to 120 volts positive and back down to 0 volts, before going to negative 120 volts and then back up to 0 volts.

This happens 60 times a second in a process commonly referred to as 120/240-volt AC 60 Hz (hertz), as shown in Figure 2.

The electricity that feeds the 120-volt AC receptacle in the motorhome comes from the 120/240-volt AC breaker panel. This panel is supplied with 240 volts AC, which comes from two 120-volt AC legs that are 180 degrees out of phase. This means that when Leg 1

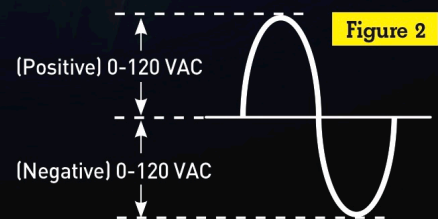

of the 120 volts AC is going from 0 to 120 volts positive (Figure 2), Leg 2 of the 120 volts AC is going from 0 to 120 volts negative (Figure 3).

To get 240 volts AC to power the larger appliances like a clothes dryer or the aftermarket CheapHeat electric-element furnace upgrade, rather than going from one hot leg to neutral (120-volt AC), power is taken from the two opposing hot legs, and since they are 180 degrees out of phase, the end result is 240 volts AC (Figure 4). Now since the neutral wire (white) isn't used in the 240-volt AC configuration, the waveform's reference is from the red to black wires rather than red to white or black to white wires, which now generates the waveform as shown in Figure 5. This means that owners looking for high-capacity clothes dryers can upgrade to units powered by 240 volts AC, something that is offered in a number of high-end motorhomes.

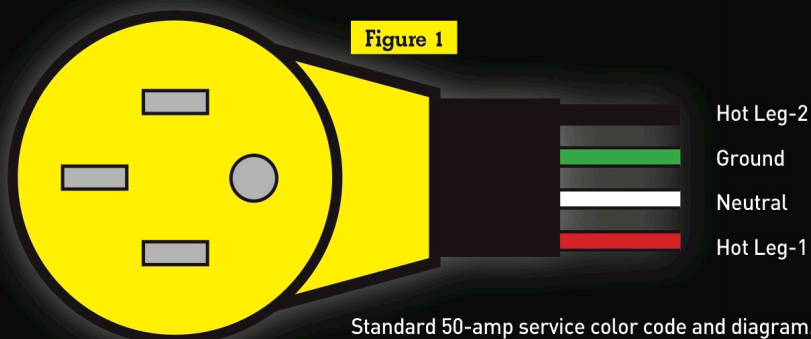

Standard 50-amp service color code and diagram.

**Figure 3**

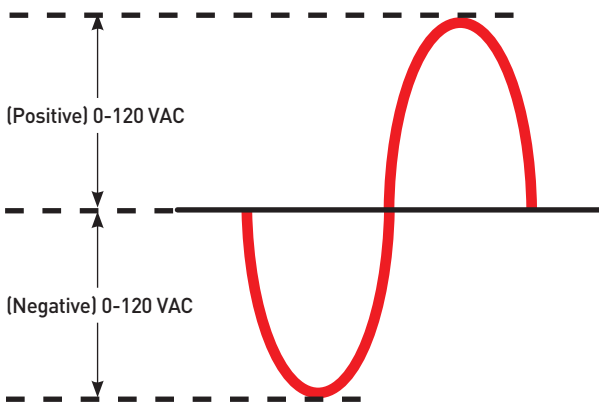

**Figure 4**

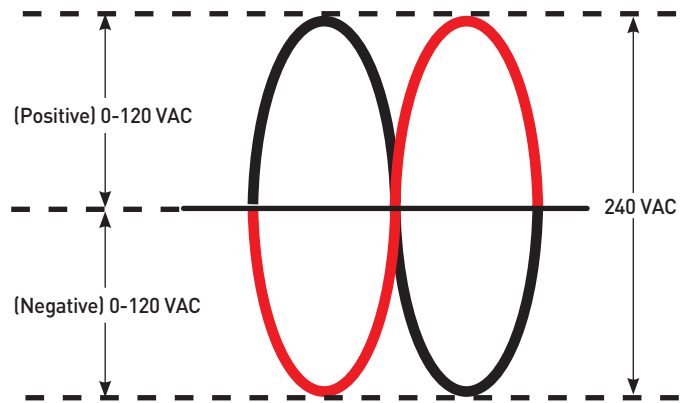

Got all that? Well, now let's review the four-wire 50-amp shorepower cord. It has four 6-gauge wires rated at 50 amps each, meaning the cord has two 50-amp legs at 120 volts AC (hot to neutral) for a total of 100 amps at 120 volts AC or one circuit of 240 volts AC at 50 amps (Leg 1 hot to Leg 2 hot), or a combination of the two.

But wait! If we have 120 volts AC at 50 amps on the red to white wires and 120 volts AC at 50 amps on the black to white wires, wouldn't that be 120 volts AC at 100 amps on the white wire since there is only one white wire? Well, that's because the two hot legs are 180 degrees out of phase. When Leg 1 electrons are moving toward positive 120 volts AC, the Leg 2 electrons are moving toward negative 120 volts AC. When correctly wired, the neutral leg will see no electron flow — and that's why it's called the Neutral Leg, and there is no overload.

If the RV park pedestal is wired incorrectly, and the two legs are not out of phase, you will have 100 amps applied to a white wire that is only rated for 50 amps. In that scenario you have both Leg 1 and 2 electrons moving toward 120 volts AC positive and negative at the same time

(Figure 6), which means you have double the electron flow [current] going through the white wire when it's only rated for half that load. The end result is an overloaded wire that will overheat and possibly cause a fire.

So, how do you know when you have an incorrectly wired shorepower pedestal? There are two simple ways to check it out. One is to install a surge protector that identifies incorrect phasing and locks out the power to the motorhome. Another way is to use a simple voltmeter that is rated to test AC voltage up to 300 volts. If the pedestal is wired correctly when you test from Leg 1 to Leg 2 (not Neutral), and if the two legs are 180 degrees out of phase as they should be, the meter will read somewhere close to 240 volts AC (Figure 7). When the shorepower pedestal is wired incorrectly, the two legs will be at the same phase. Testing from Leg 1 to Leg 2 (not Neutral), the reading will show 0 volts on the meter (Figure 8). As stated previously, this is an unsafe condition because there can be a 100-amp load on a white wire that is only rated for 50 amps. If you suspect that this condition exists, limit the use of appliances to prevent overload and report the problem to the park manager as soon as possible.

Remember that using a 30-amp to 50-amp

This adapter was subjected to a heavy load that produced high heat and melted the plastic. For safety, and to ward off any loss of power, this 30-to-15 amp adapter needs to be replaced. The easiest way to test for correct 50-amp service is to use a voltmeter across the black and red wires (the opposite slots in the plug).



Figure 5

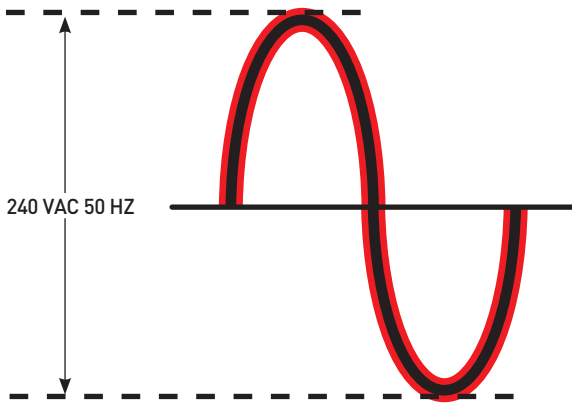
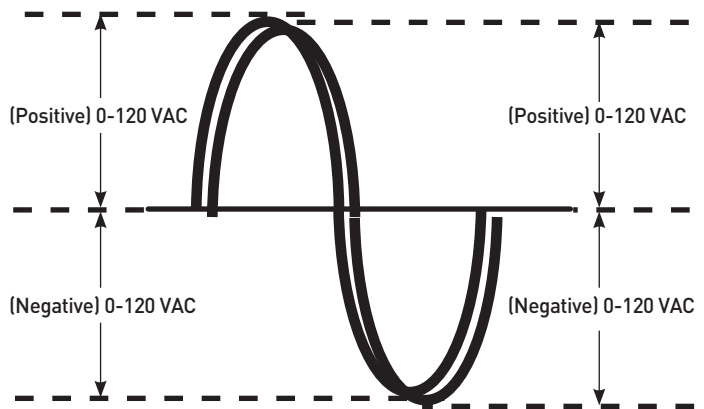

Figure 6



pigtail adapter will not allow you to see 240 volts AC in the breaker panel. In that scenario, you are just splitting the same single black hot leg on the 30-amp plug to feed both the red and black wires on the 50-amp plug.

Warning signs of an overloaded power cord often appear as melted areas around the prongs. Before plugging into park power, make it a habit to visually inspect both ends

of the cord for corroded or compromised plugs. Check the park's outlets for broken or melted portions as this can also damage the power cord. If you use an adapter from 50 to 30 amps, check for the same problems.

RV park maintenance people and owners typically shut off the 50-amp breakers in the power pedestal. Circuit breakers are not an on/off switch, and as a result over a

period of time the amperage rating diminishes because the bimetal strips lose elasticity. If you suspect the breakers trip prematurely, contact the park manager.

A simple voltmeter and a surge protector should be a part of every motorhome owner's arsenal. Modern digital meters are easy to use and will take the guesswork out of many electrical situations. **M**

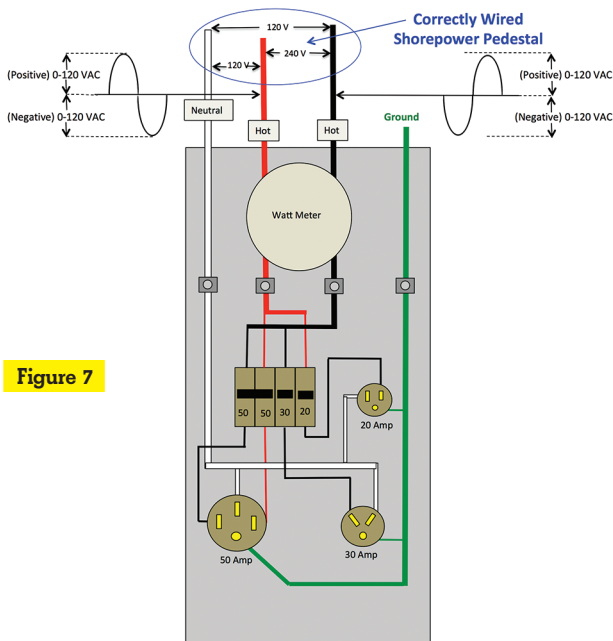

Figure 7

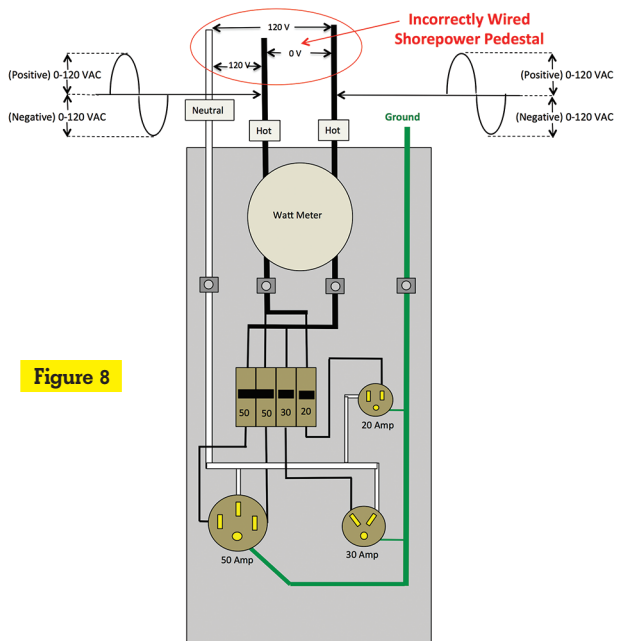

Figure 8

Thanks to Larry McGaugh RV Comfort Systems for providing the graphics and background support for this article. It's also important to note that the company's CheapHeat Electric Hybrid Furnace kit is not subject to these types of overload problems when configured to operate on 50-amp service. Along with its inherent phase protection, it also features multiple high-temperature safety systems to protect against overheating conditions. In addition, it is hard-wired directly into the motorhome's main power system, removing any potential fire hazard created by using a plug-in portable electric heater.