



RECORD THIS INFORMATION FOR FUTURE REFERENCE:

Model Number _____
Serial Number _____
Date Purchased _____
Retailer / Qualified Installer _____

SERVICE INSTRUCTIONS



DM2652
RISER KIT

RM2820
REPLACEMENT

**CONVERT DM2652 REFRIGERATOR
TO REPLACE RM2820
(TO FIT RM2820 CABINET OPENING)**



Read these instructions carefully. These instructions MUST stay with this product.

Form No. 3315716.000 02/14
(French 3315717.000)
©2014 Dometic Corporation
LaGrange, IN 46761

USA
SERVICE OFFICE
Dometic Corporation
2320 Industrial Parkway
Elkhart, IN 46516

CANADA
Dometic Corporation
46 Zatonski, Unit 3
Brantford, ON N3T 5L8
CANADA

**SERVICE CENTER &
DEALER LOCATIONS**
Please Visit:
www.eDometic.com

INTRODUCTION

This kit is designed and intended for use on DM2652 refrigerators (hereinafter referred to as “refrigerator,” or “product”). It is designed to convert a DM2652 refrigerator to fit an existing cabinet opening of an old RM2820 refrigerator. This kit can be installed by one person. Use these instructions **AND** Installation Instructions (included with refrigerator) to ensure correct installation of kit, and correct function of product. Dometic Corporation reserves the right to modify appearances and specifications without notice.

TABLE OF CONTENTS

INTRODUCTION.....	2
DOCUMENT SYMBOLS	2
IMPORTANT SAFETY INSTRUCTIONS.....	3
A. Recognize Safety Information	3
B. Understand Signal Words.....	3
C. Supplemental Directives.....	3
D. General Safety Messages	3
GENERAL INFORMATION.....	3
A. Scope Of Delivery.....	3
B. Required Tools.....	3
C. Required Components.....	3
PREPARE REFRIGERATOR	4
A. Remove Old Refrigerator.....	4
B. Replace Mounting Rails.....	4
INSTALL REFRIGERATOR	4
A. Place And Secure Refrigerator	4
CONNECT UTILITIES	5
FINISH INSTALLATION.....	6

DOCUMENT SYMBOLS

 Indicates additional information that is **NOT** related to physical injury.

 Indicates step-by-step instructions.

IMPORTANT SAFETY INSTRUCTIONS

This manual has safety information and instructions to help you eliminate or reduce the risk of accidents and injuries.

A. Recognize Safety Information



This is the safety alert symbol. It is used to alert you to potential physical injury hazards. Obey all safety messages that follow this symbol to avoid possible injury or death.

B. Understand Signal Words

A signal word will identify safety messages and property damage messages, and will indicate the degree or level of hazard seriousness.

⚠ WARNING indicates a hazardous situation that, if **NOT** avoided, could result in death or serious injury.

⚠ CAUTION indicates a hazardous situation that, if **NOT** avoided, could result in minor or moderate injury.

NOTICE is used to address practices **NOT** related to physical injury.

C. Supplemental Directives



Read and follow all safety information and instructions to avoid possible injury or death.

Read and understand these instructions before [installing / using / servicing / performing maintenance on] this product.

Incorrect [installation / operation / servicing / maintaining] of this product can lead to serious injury. Follow all instructions.

The installation **MUST** comply with all applicable local and national codes, including the latest edition of the following standards:

U.S.A.

- ANSI/NFPA70, National Electrical Code (NEC)
- ANSI/NFPA 1192, Recreational Vehicles Code
- Title 24 CFR, Part 3280, Manufactured Home Construction and Safety Standard
- National Fuel Gas Code, ANSI Z223.1/NFPA 54

CANADA

- CSA C22.1, Parts I & II, Canadian Electrical Code
- CSA Z240 RV Series, Recreational Vehicles
- CSA Z240.4, Gas-Equipped Recreational Vehicles and Mobile Housing
- CSA B149.1, Natural Gas and Propane Installation Code

D. General Safety Messages

⚠ WARNING Failure to obey the following warnings could result in death or serious injury:

- This product **MUST** be [installed / serviced] by a qualified service technician.
- Do **NOT** modify this product beyond the scope of these service instructions. Modification (beyond these service instructions) can be extremely hazardous.

GENERAL INFORMATION

A. Scope Of Delivery

- (2) Mounting Rail
- (1) Base Cover
- (1) Gas Line Extension with 45° 3/8" Flare Nipple

B. Required Tools

- Electric Drill (optional)
- Phillips Screwdriver / Bit
- Adjustable Wrench
- 5/8" Open End Wrench
- 11/16" Open End Wrench
- 3/4" Open End Wrench

 Additional tools may be necessary to complete refrigerator installation.

C. Required Components

- 3" Screws

PREPARE REFRIGERATOR

A. Remove Old Refrigerator

Remove old refrigerator from enclosure.

i See Installation Instructions (included with refrigerator) for appropriate procedure.

B. Replace Mounting Rails

1. **NOTICE** Do **NOT** allow cosmetic features / surfaces of product to contact floor or other hard surface. Otherwise, abrasion or other damage could occur.

Place new refrigerator face down to access mounting rail (at bottom).

i Use padding to protect refrigerator doors from abrasion, and boards to space refrigerator handles above floor (if applicable).

2. Remove screws securing mounting rail to refrigerator. Save for reinstallation later. See (FIG. 1).

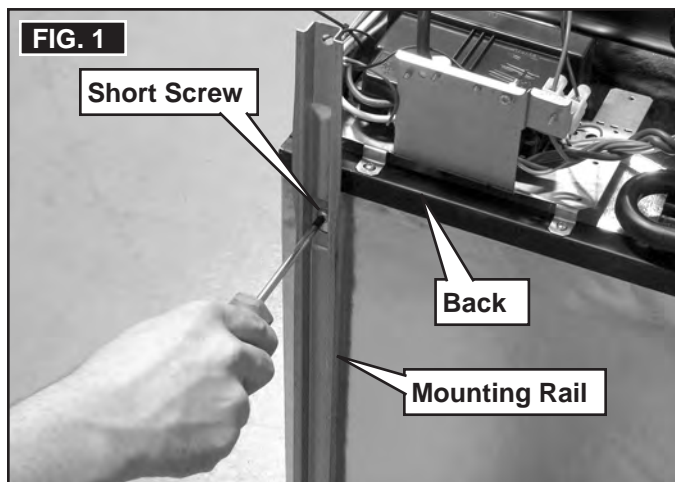

3. Discard old (short) mounting rail. See (FIG. 1).
4. Place new (tall) mounting rail against bottom of refrigerator, and align its mounting holes to the tapped holes in refrigerator. See (FIG. 2).

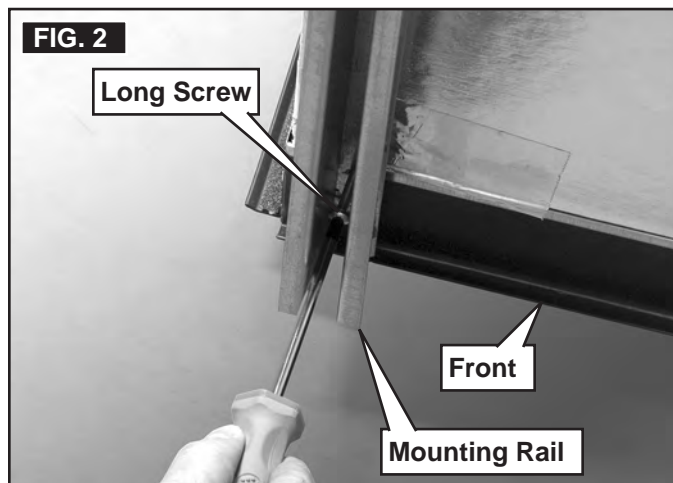

5. Reinstall screws to secure mounting rail to refrigerator. See (FIG. 1) & (FIG. 2).
i Short screw near back of refrigerator, and long screw near front.
6. Repeat steps (2) through (5) for other mounting rail.

INSTALL REFRIGERATOR

Make sure refrigerator enclosure is prepared correctly before installing refrigerator.

i See Installation Instructions (included with refrigerator) for enclosure requirements.

Enclosure size should match requirements for the RM2820 refrigerator.

A. Place And Secure Refrigerator

1. Verify electrical outlet (inside enclosure) will not interfere with refrigerator installation.

i If outlet location interferes, move / reroute wiring to appropriate location in compliance with all applicable codes.

2. Carefully place and secure refrigerator to enclosure.

i Verify there are no exposed openings / gaps along top and sides where refrigerator frame seals against enclosure.

See Installation Instructions (included with refrigerator) for complete instructions.

Exceptions to normal instructions:

- Use 3" long mounting screws (customer supplied) through (tall) mounting rail. See (FIG. 3) & (FIG. 4).
- Discard old (short) base cover (included with refrigerator). Use new (tall) base cover (provided with kit) instead. See (FIG. 4).

INSTALL REFRIGERATOR

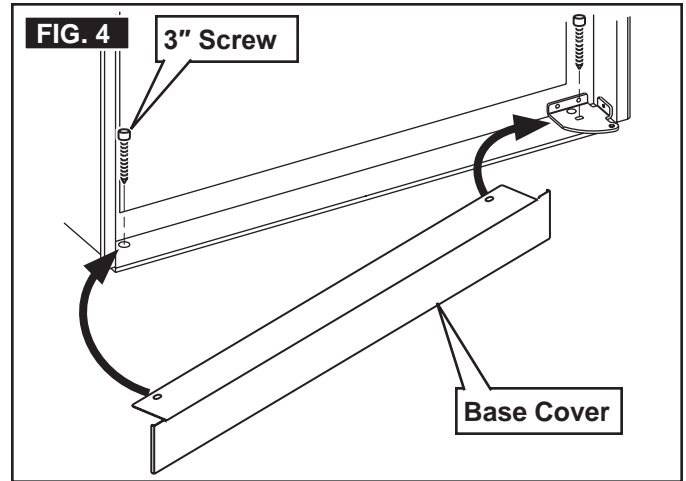
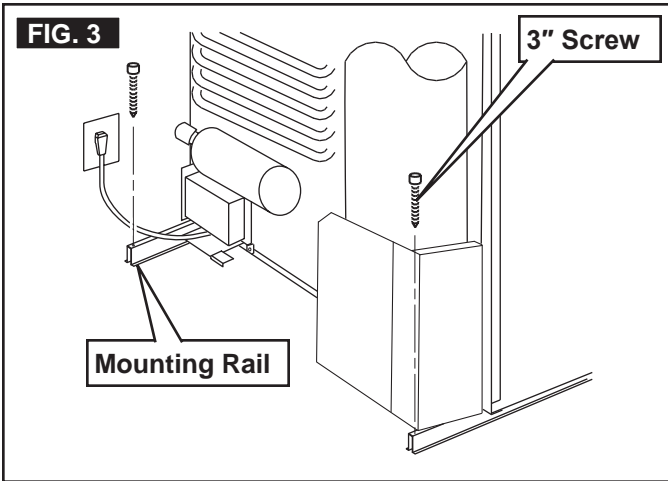

CONNECT UTILITIES

1. Connect water (if applicable) and electric services to refrigerator.

i See Installation Instructions (included with refrigerator) for complete instructions.

2. **NOTICE** ALWAYS use a backup wrench when loosening or tightening LP gas connections.

Connect LP gas service.

i See Installation Instructions (included with refrigerator) for complete instructions.

a. If RV LP gas line is long enough to reach LP gas valve on refrigerator, skip to section "Finish Installation" on page (6).

i Gas line extension is **NOT** needed if existing RV LP gas line is long enough.

b. If RV LP gas line does not reach LP gas valve on refrigerator, proceed to step (c).

c. Connect gas line extension to RV LP gas line. See (FIG. 5) & (FIG. 6).

- Place and tighten 3/8" flare nipple (provided with gas line extension) into flare nut of RV LP gas line.

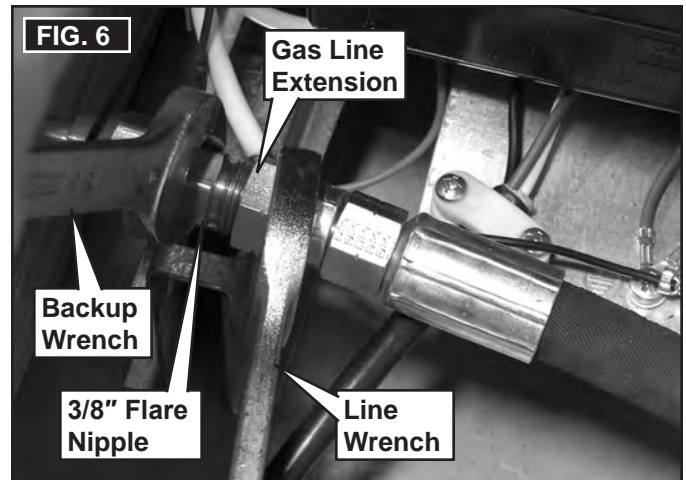

d. Connect gas line extension to LP gas valve on refrigerator. See (FIG. 7).

i It may be necessary to loop gas line extension.

- Place and tighten flare nut of gas line extension (provided) onto 3/8" male flare end of refrigerator LP gas valve.

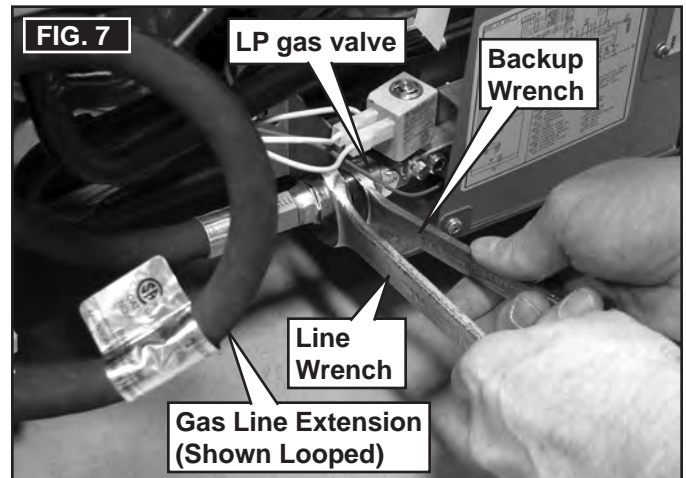
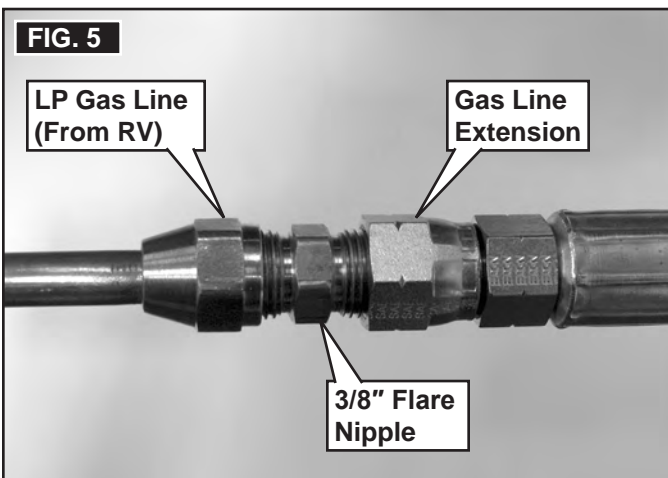

FINISH INSTALLATION

 Additional procedures **MUST** be performed to complete installation. See Installation Instructions (included with refrigerator).

Additional procedures may include:

- Install trim, door panels, and door handles.
- Verify refrigerator is sealed correctly to isolate combustion system from RV interior.
- Route drain hose.
- Check for gas leaks.
- Test refrigerator operation.

This manual has been provided courtesy of
My RV Works, Inc.

www.myrvworks.com



You can find more RV service manuals here:

www.myrvworks.com/manuals

Over the years of running a mobile RV repair service, having a dedicated place to access service manuals for all the different appliances and components found on RVs was something that I always had a desire to create.

I hope this resource makes your RV repairs easier, as it has mine, but please be careful and follow proper safety practices when attempting to repair your own RV.

If in doubt, please consult with a professional RV technician!



DARREN KOEPP - OWNER, MY RV WORKS, INC.

All service manuals provided on www.myrvworks.com are believed to be released for distribution and/or in the public domain.