

RM2351 RM2454 DM2652 DM2852
RM2354 RM2551 DM2662 DM2862
RM2451 RM2554 DM2663 NDM1062

FOR YOUR SAFETY

If you smell gas:

1. Open windows.
2. Don't touch electrical switches.
3. Extinguish any open flame.
4. Immediately call your gas supplier.

PAR MESURE DE SÉCURITÉ

Si on détecte une odeur de gaz :

1. Ouvrir les fenêtres.
2. Ne pas toucher les commutateurs électriques.
3. Éteindre toute flamme nue.
4. Contacter immédiatement le fournisseur de gaz.

FOR YOUR SAFETY

Do not store or use gasoline or other flammable vapors and liquids in the vicinity of this or any other appliance.

PAR MESURE DE SÉCURITÉ

Ne pas entreposer ou utiliser de l'essence ou autre vapeur ou liquide inflammable au voisinage de cet appareil ou de tout autre appareil ménager.

⚠ WARNING

Improper installation, adjustment, alteration, service or maintenance can cause injury or property damage. Refer to this manual. For assistance or additional information consult a qualified installer, service agency or the gas supplier.

⚠ AVERTISSEMENT

Une installation, un réglage, une modification, un dépannage ou un entretien effectués incorrectement, peuvent provoquer des blessures ou des dommages matériels. Se reporter à ce manuel. Pour obtenir une aide ou des informations complémentaires, consulter un installateur qualifié, une entreprise de dépannage ou le fournisseur de gaz.

⚠ WARNING

If the refrigerator stops cooling - or - if it emits an ammonia smell, immediately turn the refrigerator off and contact a Service Center.

⚠ AVERTISSEMENT

Si le réfrigérateur cesse de refroidir - ou - s'il s'en dégage une odeur d'ammoniac, arrêter immédiatement le réfrigérateur et contacter un centre de service après-vente.

REVISION

Form No. 3313240.016 6/11
(Replaces 3313240.000)
(French 3313241.013)
©2011 Dometic, LLC
LaGrange, IN 46761

USA

Dometic, LLC
Service Office
2320 Industrial Pkwy.
Elkhart, IN 46516
Phone: 574-294-2511

CANADA

Dometic, LLC
48 Zatonski, Unit 3
Brantford, ON N3T 5L8
CANADA
Phone: 519-720-9578

Corporate Office
2320 Industrial Parkway
Elkhart, IN 46516

**For Service Center
Assistance**
Call: 800-544-4881

INTRODUCTION

Thank you for purchasing a new Dometic refrigerator. This product is a recreational vehicle refrigerator intended for the storage of fresh and frozen foods, as well as making ice. Please read and be aware of possible safety hazards identified in this manual, and become familiar with the alert symbols on the refrigerator. Read this manual carefully so that you know how to operate the refrigerator safely and correctly. Keep this manual with the refrigerator for future reference.

CONTENTS

REFRIGERATOR OVERVIEW	4
INSTRUCTIONS FOR USE	7
STORAGE COMPARTMENTS	10
PRODUCT CARE	11
MAINTENANCE & SERVICE	13
REFRIGERATOR REMOVAL	14
TROUBLESHOOTING	15
APPENDIX A - SPARE PARTS	16
APPENDIX B - REARVIEW EQUIPMENT	18
APPENDIX C - WIRING DIAGRAM	20
APPENDIX D - CONSUMER SUPPORT	25
APPENDIX E - DOMETIC WARRANTY	26
APPENDIX F - MAINTENANCE SCHEDULE	27
NOTES	28

SYMBOLS

The following symbols are used throughout this manual:



This is the safety alert symbol. It is used to alert you to personal injury hazards. Obey all safety messages that follow this symbol to avoid possible injury or death.



WARNING indicates a hazardous situation which, if not avoided, could result in death or serious injury.



CAUTION, used with the safety alert symbol, indicates a hazardous situation which, if not avoided, could result in minor or moderate injury.

NOTICE

NOTICE is used to address practices not related to personal injury.



Information



Step-by-step instructions

REFRIGERATOR OVERVIEW

ABSORPTION COOLING SYSTEM

 When turning on the refrigerator, you should adjust the thermostat (excludes RM2351, RM2451, RM2551, DM2652 & DM2852 - not adjustable) to the coldest temperature setting. The cooling cycle may require an extended running time before cooling effect is observed.

LEVELING THE REFRIGERATOR

Leveling is one of the requirements for proper operation with absorption refrigerators. To ensure proper leveling the vehicle needs to be leveled so it is comfortable to live in (no noticeable sloping of floor or walls).

Any time the vehicle is parked for several hours with the refrigerator operating, the vehicle should be leveled to allow proper cooling.

When the vehicle is moving, the leveling is not critical, as the rolling and pitching movement of the vehicle will pass to either side of level, keeping the liquid ammonia from accumulating in the evaporator tubing.

PURGING AIR FROM THE LINES

If the refrigerator has not been used for a long time - or - the LP tanks have just been refilled, air may be trapped in the supply lines. To purge the air from the lines, turn the refrigerator off and on by pressing the ON/OFF button. If the flame is not lit within 45 seconds, turn the refrigerator off and back on again. This procedure can be repeated 3 to 4 times. If repeated attempts fail to start the LP gas operation, check to make sure that the LP gas supply tanks are not empty and that all manual shutoff valves in the lines are open. If the problem persists, turn the refrigerator off and take it to a Service Center.

WHEN THE REFRIGERATOR IS NOT IN USE

Any absorption refrigerator that is to be taken out of service for an extended period of time should be turned off.

 It is important that you do not leave the refrigerator to run idle and/or unattended for days or weeks.

AUTOMATIC ENERGY SELECTOR SYSTEM

The refrigerator is equipped with an automatic energy selector system. The user turns the refrigerator on and then, the refrigerator automatically selects the most suitable energy source available, either 120 VAC or LP gas operation. The system can be set by the user to be fully automatic (AUTO mode is selected) or to operate on LP gas only (AUTO mode is off).

On 3-way models, the control system can manually be set to DC mode (DC operation). The DC mode overrides all other operating modes.

The refrigerator controls will work down to 9.6 VDC.

REFRIGERATOR OVERVIEW

CONTROL PANEL

RM2351, RM2451, RM2551, DM2652 & DM2852

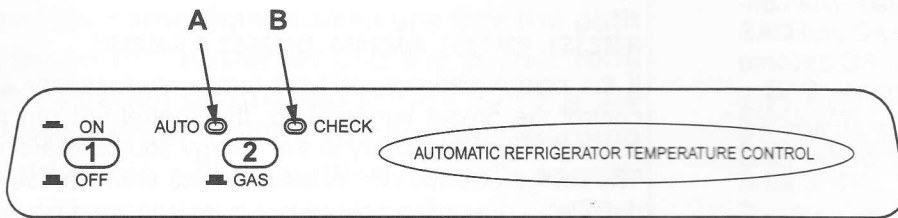

1. ON/OFF button (main power)
2. AUTO/GAS mode selector button
- A. AUTO mode indicator lamp
- B. CHECK indicator lamp (GAS mode only)

RM2354, RM2454, RM2554 & DM2663

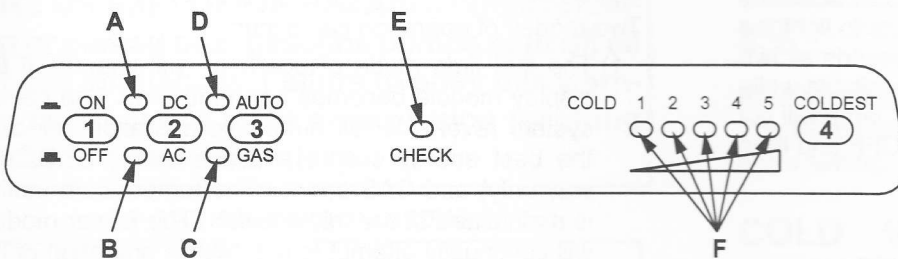

1. ON/OFF button (main power)
2. DC mode selector button
3. AUTO/GAS mode selector button
4. Temperature selector button
- A. DC mode indicator lamp
- B. AC mode indicator lamp
- C. GAS mode indicator lamp
- D. AUTO mode indicator lamp
- E. CHECK indicator lamp (GAS mode only)
- F. Temperature indicator lamps

DM2662, DM2862 & NDM1062

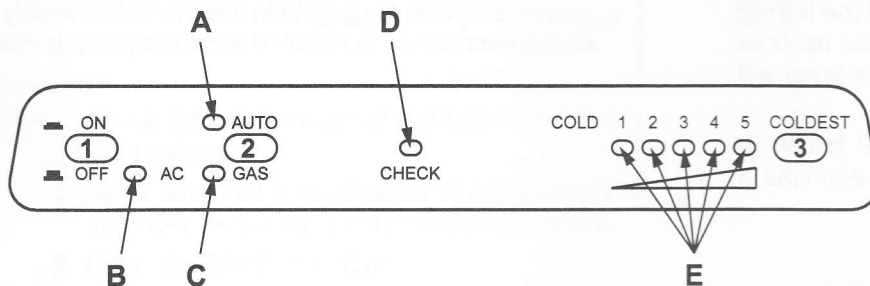

1. ON/OFF button (main power)
2. AUTO/GAS mode selector button
3. Temperature selector button
- A. AUTO mode indicator lamp
- B. AC mode indicator lamp
- C. GAS mode indicator lamp
- D. CHECK indicator lamp
- E. Temperature indicator lamps

NDM1062

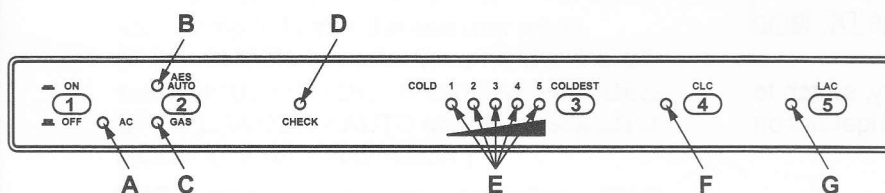

1. ON/OFF button (main power)
2. AES/AUTO/GAS mode selector button
3. Temperature selector button
4. Climate control button
5. Low ambient control button
- A. AC mode indicator lamp
- B. AES/AUTO mode indicator lamp
- C. GAS mode indicator lamp
- D. CHECK indicator lamp
- E. Temperature indicator lamps
- F. Climate control indicator lamp
- G. Low ambient control indicator lamp

REFRIGERATOR OVERVIEW

MODES OF OPERATION

AUTO MODE - AES/AUTO MODE

When operating in AUTO - AES/AUTO mode, the AUTO - AES/AUTO mode indicator lamp is illuminated. The control system will automatically select between AC and GAS operation. AC has priority over GAS. Should AC become unavailable, the system automatically switches to GAS.

As soon as AC becomes available again, the control will switch back to AC regardless of the status of the GAS operation.

If the CHECK indicator lamp is illuminated the controls have failed to ignite the burner in the GAS mode. To restart an ignition attempt with the CHECK lamp illuminated (or to turn off the CHECK lamp), press the ON/OFF button OFF and back ON again. The control system activates the ignition system and makes three attempts to light the burner for a period of approximately 45 seconds at two minutes interval. Should 120 VAC become available while the CHECK indicator lamp is on, the CHECK lamp will *not* turn off until the ON/OFF button is pressed OFF and then ON again.

GAS MODE

RM2351, RM2451, RM2551, DM2652 & DM2852:

When operating in GAS mode, the AUTO mode indicator lamp will be off.

RM2354, RM2454, RM2554, DM2662, DM2663, DM2862 & NDM1062: When operating in GAS mode, the GAS Mode indicator lamp is illuminated.

This mode provides LP gas only. The control system activates the ignition system and attempts to light the burner for a period of approximately 45 seconds at two minutes interval. If unsuccessful, the CHECK indicator lamp will illuminate.

To restart GAS operation, press the ON/OFF button to OFF and then back ON. The control system attempts a new ignition sequence.

DC MODE

RM2354, RM2454, RM2554 & DM2663

When operating in DC mode (3-way models only), the DC mode indicator lamp is illuminated and all other lamps are off. To select another operating mode, turn off the DC mode by pressing the DC selector button. The DC lamp is turned off.

When there is no charging of the house battery, switch to AUTO mode or GAS mode since running the refrigerator on 12 VDC will quickly drain the battery.

LIMP MODE OF OPERATION

In the event of a failure of a major operating component, the control system will continue to operate the cooling system.

RM2351, RM2451, RM2551, DM2652 & DM2852

If the control can not read the temperature sensor and control the preset temperature, the control will run the cooling unit continuously at the energy source available. The refrigerator will continue to operate in this mode indefinitely - or - until a new sensor is installed and the system reset.

RM2354, RM2454, RM2554, DM2662, DM2663, DM2862 & NDM1062

Two modes of operation can occur:

- 1) The first limp mode of operation will execute if the display module becomes non functional. The control system reverts to full automatic operation selecting the best energy source available with AC, DC (3-way only) and GAS priority. The temperature setting is maintained at the mid position. The power module will continually attempt to reestablish operation of the display module.
- 2) The second limp mode of operation will execute when a failure of the temperature sensing device or associated electronic circuitry occurs. If this should happen, the control system operates on the energy source selected via the control panel. The cooling unit runs continuously on the selected energy source. The refrigerator continues to operate in this mode indefinitely or until a new sensor is installed and the system is reset.

INSTRUCTIONS FOR USE

STARTING THE REFRIGERATOR

⚠ WARNING

FIRE HAZARD. When the RV has not been used for some time, make sure that the path between the burner jet and the burner tube has not been obstructed before lighting the LP gas burner. Failure to obey this warning could cause a fire resulting in death or serious injury.

⚠ WARNING

FIRE OR EXPLOSION HAZARD. When refueling or parked near gasoline pumps shut off all LP gas appliances. Failure to obey this warning could cause a fire or explosion resulting in death or serious injury

LP GAS EQUIPMENT ASSEMBLY

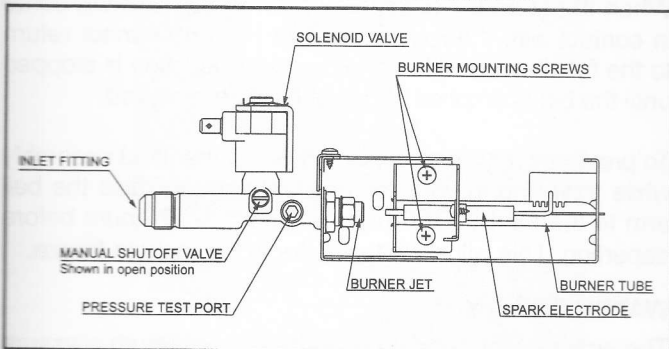

1. Check that all the manual gas valves are in the ON position.
2. Make sure that a continuous 12 VDC supply is available for the electronic control to function.
3. Press the ON/OFF button.
4. Select operation mode:
 - **AUTO - AES/AUTO mode** (AC and Gas)
Press the AUTO/GAS - AES/AUTO/Gas mode selector button (if not already on). The illuminated lamp indicates the selected mode. (If the CHECK indicator lamp is illuminated, see REFRIGERATOR OVERVIEW > MODES OF OPERATION > AUTO MODE - AES/AUTO MODE for further information.)
 - **GAS mode** (LP gas operation only)
Press the AUTO/GAS - AES/AUTO/Gas mode selector button to turn off the AUTO mode (if not already off).
(Within 45 seconds the burner should be ignited and operating normally. If not, see REFRIGERATOR OVERVIEW > MODES OF OPERATION > GAS MODE for further information.)

- **DC mode** (3-way models only)

Press the DC mode indicator button. The DC lamp will be turned on. To select AUTO or GAS mode, turn off the DC mode by pressing the DC mode selector button. The DC lamp will then be turned off.

ADJUSTING THE THERMOSTAT

RM2354, RM 2454, RM2554, DM2662, DM2663, DM2862 & NDM1062

The thermostat controls both the gas and electric operation, thereby eliminating the necessity of resetting each time a different energy source is employed. After the initial start-up, the thermostat should be adjusted to the desired temperature setting.

1. Press the temperature selector button until the lamp at the desired setting is illuminated.

RM2351, RM2451, RM2551, DM2652 & DM2852

The temperature is controlled by a factory preset temperature setting.

COLD WEATHER LOW AMBIENT CONTROL

NDM1062

The refrigerator is equipped with an exclusive feature that allows for trouble-free operation in low ambient temperature (like below 50°F) for extended periods of time. Once the outdoor temperature is above 50°F, the low ambient switch should be turned off.

1. Turn the Low ambient control switch to I (ON).

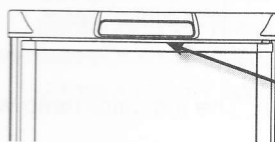

The Low ambient control switch is located beneath the top decoration panel that houses the control panel.

2. Press the LAC button. The indicator lamp will illuminate.

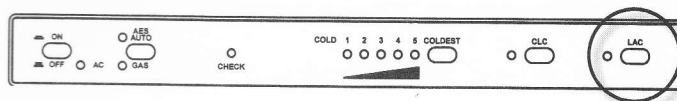

INSTRUCTIONS FOR USE

EXTREME COLD WEATHER OPERATION

Refrigerator performance may be reduced in extremely cold (subzero) temperatures. This temporary condition is normal for absorption refrigerators and does not indicate product failure. In the event that performance is reduced in such conditions, turn the refrigerator off. As ambient temperatures rise, please restart your refrigerator according to instructions before requesting service.

CLIMATE CONTROL SYSTEM

NDM1062

During the summer months of high temperature and humidity, the metal frame between the freezer and fresh food compartments may have water droplets forming. The number of water droplets will increase if the vehicle is not air conditioned during these months. The refrigerator comes standard with a 12 VDC climate control that will evaporate the water droplets when they form. The climate control can be left on continuously or used only when temperatures require it. Note that when turned on, the climate control will draw 12 VDC power continuously. Turn it off when a charging source is not available.

-  1. Turn the climate control switch to I (ON).

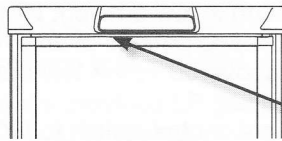

The Climate control switch is located beneath the top decoration panel that houses the control panel.

2. Press the CLC button. The indicator lamp will illuminate.

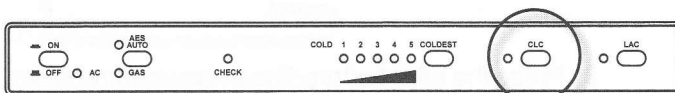

OPERATING THE ICE MAKER

NDM1062 WITH ICE MAKER

Before the ice maker can operate, make sure that:

- The refrigerator is connected to 120 VAC .
- The water valve supplying the refrigerator is turned on.
- The ice level bail arm is in its fully down position.

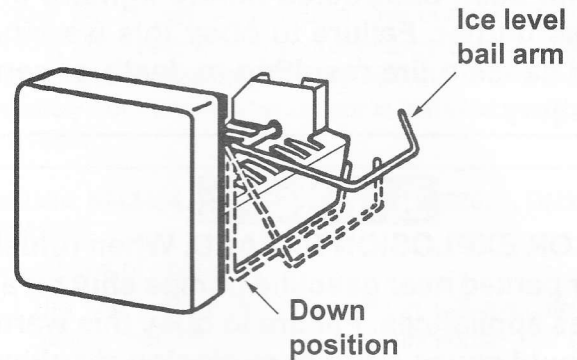

When the ice maker thermostat senses the preset temperature for the ejection of the ice cubes, the fingers will start to rotate, dumping any ice cubes and filling the mold with water. When the storage container is full, the bail arm will come in contact with the ice cubes. The bail arm cannot return to the full down position and the ice production is stopped until the bin is emptied, or ice cubes are removed.

To prevent water from splashing out of the mold assembly while travelling in your recreational vehicle, raise the bail arm to the full UP/OFF position about 1-1/2 hours before departing. This will allow the water in the mold to freeze.

WATER SUPPLY

The water supply system must have a minimum pressure of 15 pounds per square inch gauge (psig). A 1/4" diameter water line to the water valve should be used at the rear of the refrigerator. The water line must have a manual shutoff valve placed where it is easily accessible.

The maximum water level is represented by a thin line. It is essential that the water level does not exceed this line!

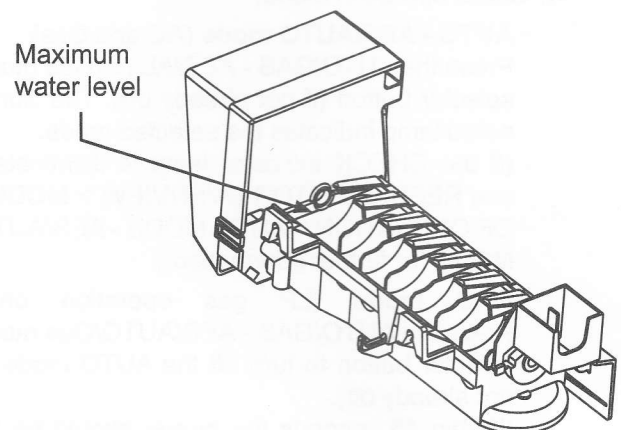

If necessary, change the water flow by adjusting the water supply. For instructions, see ADJUSTING THE SIZE OF CUBES.

INSTRUCTIONS FOR USE

ADJUSTING THE SIZE OF CUBES

i If the ice maker was cleaned and drained, no ice cubes will be dumped into the bin during the first cycle.

The first few cycles may have small cubes due to air trapped in the water lines. The first container of ice cubes should be dumped if the water system has been winterized or not used for several weeks. Once the ice maker has run through several cycles and if cubes are too small or sticking together, adjustment is necessary on the amount of water entering the mold.

TO ADJUST THE SIZE OF CUBES, FOLLOW THESE STEPS:

- i** 1. Remove the protective cover from the ice maker mechanism. Using a flat-head screwdriver, place the tip of the screwdriver in the slot. Twist the screwdriver blade gently to loosen the cover.

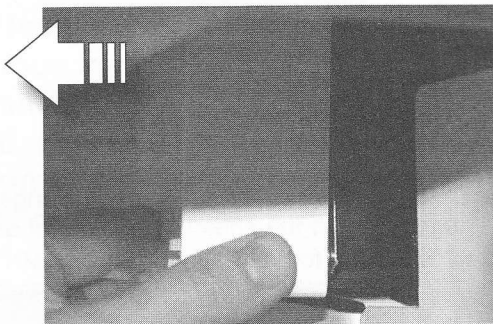
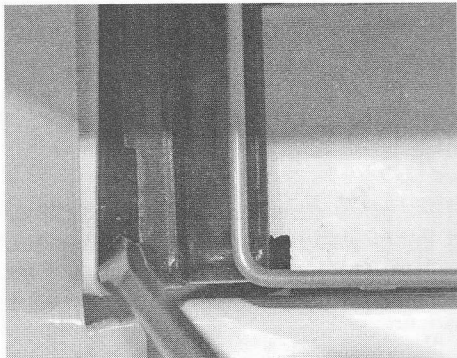

2. Locate the adjusting screw under the protective cover. Turn the screw counterclockwise to increase the size of cubes.

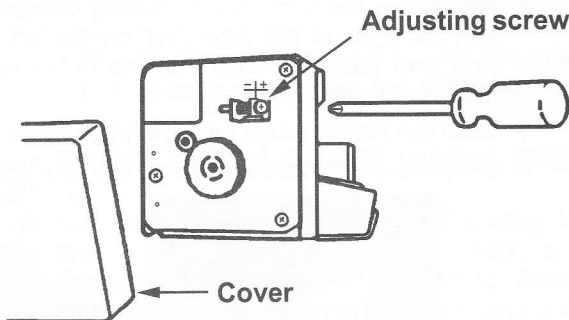

3. Turn the screw clockwise to decrease the cube size or if the mold is overfilling, and the cubes are stuck together.

i To prevent overfilling, do not turn the adjustment screw more than one revolution at a time. Allow the ice maker to cycle several times before another adjustment is made. Be sure to replace the protective cover on the cycle after the adjustments are complete.

TURNING OFF THE REFRIGERATOR, AND WHEN NOT IN USE

You can turn off your refrigerator by pressing the main power ON/OFF button found on the control panel to the OFF position. This will shut off all power to the refrigerator, including DC power to the refrigerator.

If the refrigerator will not be in operation for an extended period of time or put into winter storage it should be emptied, defrosted, cleaned, and the doors placed in the airing position. If ice cube trays are in use, they should also be dried and kept outside the cabinet.

NOTICE

This refrigerator is intended for continuous use. Do not allow it to run unattended when there is a risk for loss of electricity or fuel. Food spoilage could occur.

i The refrigerator's control system still consumes a few milliamps even if it is turned off. If your RV is being put into winter storage, it is recommended to either put your RV batteries on a battery charger or turn off the vehicle's main 12 VDC switch. This will prevent the RV battery from discharging.

STORAGE COMPARTMENTS

⚠ WARNING

FIRE OR EXPLOSION HAZARD. Do not store or use gasoline, oil or gasoline soaked rags, or other flammable vapors and liquids in the service area behind the refrigerator or in the vicinity of this or any other gas appliance. Failure to obey this warning could cause a fire or an explosion resulting in death or serious injury.

REFRIGERATOR VOLUME

MODEL	TOTAL REFRIGERATED VOLUME (CU.FT)
RM2351 & RM2354	3
RM2451 & RM2454	4
RM2551 & RM2554	5
DM2652, DM2662 & DM2663	6
DM2852 & DM2862	8
NDM1062	9.2

FOOD STORAGE COMPARTMENT

- Cool the refrigerator before placing any food inside. Never put hot food or drinks into the refrigerator - cool them first.
- The food storage compartment is completely closed and unventilated, which is necessary to maintain the required low temperature for food storage. Consequently, foods having a strong odor or those that absorb odors easily should be covered.
- Vegetables, salads, etc. should be covered to retain their crispness.
- The coldest positions in the refrigerator are under the cooling fins and at the bottom of the refrigerator. The warmer areas are on the upper door shelves. This should be considered when placing different types of food in the refrigerator.
- Arrange all food in the unit to allow for free air circulation. Do not overpack because a stuffed refrigerator must work harder and will have higher cabinet temperatures.
- Do not leave the unit's door open any longer than necessary. This will reduce frost formation and increase the efficiency of the refrigerator.

FROZEN FOOD STORAGE COMPARTMENT

This compartment is not designed for deep or quick freezing of food.

- To prevent food from drying out, keep it in covered dishes, containers, plastic bags or wrapped in aluminum foil.
- Meat or fish, whether raw or prepared, can be stored in the frozen food storage compartment provided they are precooled first in the refrigerator. They can be stored about three times longer in the frozen food compartment as compared to the fresh food compartment.
- Quick frozen soft fruits and ice cream should be placed in the coldest part of the compartment, which is at the bottom of the aluminum liner.
- Frozen vegetables, may be stored in any part of the compartment.
- To prevent frost buildup, which can reduce the efficiency, wipe excess moisture off items being placed in the compartment.

REMOVING AND REPLACING THE SHELVES

-  1. Remove the shelf locks by inserting the tip of a flat bladed screwdriver into the slot of the locks. Turn the screwdriver counterclockwise and then remove the shelf locks from the wire shelf.

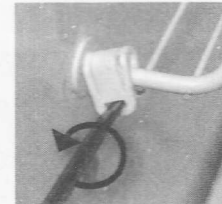

2. Slide the shelf to the left until bushings disengage, then tilt the shelf to one side at an angle while pulling forward.

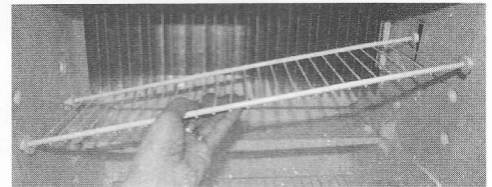

3. Reposition the shelf in the desired location. Insert the ends of the wire shelf on the left-hand side and slide the shelf into the holes on the right-hand side.
4. Slide the plastic plugs into the holes of the wall.
5. Snap the shelf locks back onto the wire shelf.

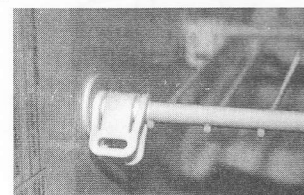

STORAGE COMPARTMENTS

ICE CUBES



Ice cubes can be made in the freezer compartment. For faster freezing, place trays in direct contact with the bottom of the freezer compartment.

RM2351, RM2454, RM2554, DM2662, DM2663, DM2862 & NDM1062

Ice will be made more rapidly if the thermostat is set at its highest position, but be sure to move the thermostat back to normal setting when ice is formed; the refrigerator might otherwise become too cold.

PRODUCT CARE

DEFROSTING

-  1. Shut off the refrigerator by pressing the main power ON/OFF button (OFF position).
 2. Empty the refrigerator.
 3. Leave the cabinet and freezer doors open and make sure the drip tray is in place under the finned evaporator.
-  Defrosting time can be reduced by filling ice trays with hot water and placing them in the freezer compartment.

WARNING

FIRE AND INHALATION HAZARD. Do not use a knife, ice pick, or any other sharp tool to remove frost from the freezer compartment. Failure to obey this warning could cause a leak in the ammonia cooling system which could lead to a fire hazard resulting in death or serious injury.

An ammonia leak also poses an inhalation hazard, and could cause chemical burns to the skin and eyes. Exposure to a high concentration of ammonia could result in death or serious injury.

NOTICE

Do not use a hot air blower to remove frost from the freezer compartment. Permanent damage could result from warping the metal or plastic parts.

4. When all the frost has melted, dry the interior with a clean cloth and turn the refrigerator back on.

RM2354, RM2454, RM2554, DM2662, DM2663, DM2862 & NDM1062

5. Set the thermostat to the coldest setting for a few hours. Then, reset the thermostat to the desired setting, usually at mid setting. Replace food after refrigerator has reached appropriate cool temperature.

AIRING POSITION

DM2652, DM2662, DM2663, DM2852 & DM2862

Use the airing position card to keep the doors ajar if the refrigerator is put in storage or will not be used for an extended period of time.

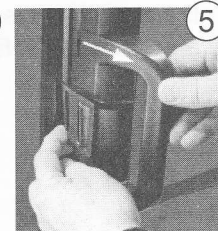
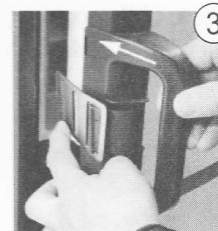
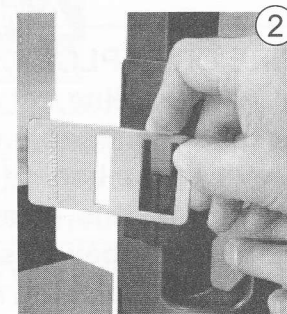
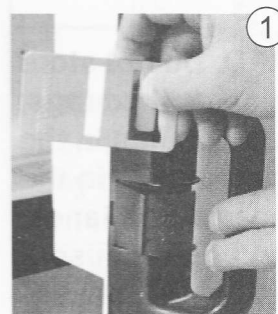
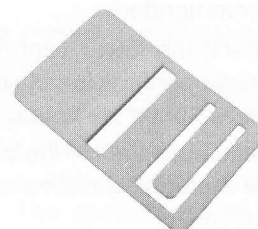

PRODUCT CARE

CLEANING

Always keep the refrigerator clean. Cleaning the refrigerator is usually done after it is defrosted or put into storage. Use a lukewarm, weak soda solution to clean the interior liner of the refrigerator. Use warm water only to clean the finned evaporator, gasket, and shelves. Do not spray liquids near electrical outlets, connections, or the refrigerator components.

NOTICE

Do not use strong chemicals or abrasives to clean these parts, as the protective surfaces will be damaged.

To keep the refrigerator operating efficiently, periodic inspection and cleaning of several components once a year is recommended:

- Check the lower vent, upper vent and area between these openings for any obstructions such as bird/insect nests, spider webs, etc.
- Make sure the refrigerator area is free from combustible material, gasoline and other flammable vapors or liquids.

⚠ WARNING

FIRE OR EXPLOSION HAZARD. Do not store or use gasoline, oil or gasoline soaked rags, or other flammable vapors and liquids in the service area behind the refrigerator or in the vicinity of this or any other gas appliance. Failure to obey this warning could cause a fire or an explosion resulting in death or serious injury.

- If accessible, clean the coils on the back of the refrigerator. Use a soft bristled brush to dust off the coils.

STORAGE PROCEDURE/WINTERIZING THE REFRIGERATOR NDM1062 WITH ICE MAKER

The refrigerator is equipped with a heater tape wrapped around the water solenoid valve and outlet water tube. During cold weather operation below 32°F/0°C the automatic temperature switch will turn the heater tape on automatically.

If the RV will not be in use for an extended period of time or put into storage:

- Drain the RV water system.
- Disconnect the water lines from the inlet and outlet sides of the water valve. Drain the lines into a cup and allow the lines to dry.
- The ice maker should be drained and dried. Note that this procedure must be performed by a qualified service technician.
- Using a lukewarm soda solution, clean the interior liner of the refrigerator. Clean the finned evaporator and shelves. Use warm water only and never strong chemicals or abrasives since these can damage the protective surfaces.
- Place doors in the airing position.

MAINTENANCE & SERVICE

-  To keep the refrigerator working properly, a qualified service technician should, at least once a year, inspect the connections, the control system, the LP gas pressure and flue baffle.

WARNING

FIRE AND INHALATION HAZARD. If the refrigerator stops working -or- if it emits an ammonia smell, immediately turn the refrigerator off, leave the vicinity, and contact a Service Center.

A high concentration of ammonia refrigerant could cause an inhalation hazard, could cause chemical burns to the skin and eyes, and could cause a fire resulting in death or serious injury.

REPLACING THE FUSES

2-way models are equipped with 2 fuses - one for the refrigerator control system and one for the AC heater.

3-way models are equipped with 3 fuses - two fuses in the power module and one in-line blade fuse.

Control system	3 A
AC heater	5 A
12 VDC heater	30 A

REPLACING THE FUSES

POWER MODULE

To replace the fuses, follow these steps:

-  1. Turn off the refrigerator and unplug the power cord and disconnect the 12V wires.
2. Remove the power module cover.
3. Snap the fuse out of the fuse holder and fit the new fuse in to the fuse holder.
4. Put back the power module cover.

DM2652 (OPTIONAL FAN), DM2852 (OPTIONAL FAN), DM2862 (OPTIONAL FAN) & NDM1062

INLINE FUSE

The inline fuse for the power vent fans is connected to the 12V DC socket.

To replace the inline fuse, follow these steps:

-  1. Disconnect 12V DC power.
2. Open the fuse holder.



3. Replace the fuse.



4. Put the holder back together.



PERIODIC MAINTENANCE

-  To be performed by a qualified service technician only.

CHECKING THE LP GAS CONNECTIONS

-  1. Check all connections in the LP gas system (at the back of the refrigerator) for gas leaks. The LP gas supply must be turned on.
2. Apply an approved leak detection solution to all LP gas connections. The appearance of bubbles indicates a leak and should be repaired immediately!

WARNING

FIRE OR EXPLOSION HAZARD. Never use an open flame to check for gas leaks. Failure to obey this warning could cause a fire or explosion resulting in death or serious injury.

CHECKING THE CONTROL SYSTEM

Check the control system by connecting/disconnecting the 120 VAC power, starting/stopping the engine, etc.

MAINTENANCE & SERVICE

CLEANING THE BURNER

1. Turn off the refrigerator
2. Unplug the power cord from the 120 VAC outlet. Disconnect the wires or shut off the 12 VDC power supply to the refrigerator.
3. Turn off the manual shut off valve.
4. Remove cover from burner housing.
5. Clean the burner tube with a brush. Blow out the burner with compressed air.

⚠ WARNING

FIRE HAZARD. Never use a wire or pin to clear obstructions from the burner jet as damage will occur. Do not attempt to adjust the burner jet. Failure to obey this warning could cause a fire resulting in death or serious injury.

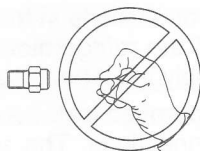

6. Verify that the burner jet slots are centered under the flue tube.

7. Be sure to check the burner flame for proper appearance. The flame should be clear blue over the slots of the burner.

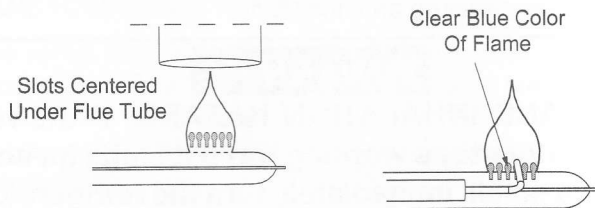

8. Check the electrode for proper location and gap. Adjustments may be made with needle nose pliers if necessary.

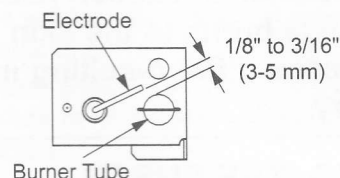

9. Turn on the manual gas shut off valve.
10. Examine all fittings for leaks. Use a commercial non-corrosive bubble solution.
11. Connect the 120 VAC power cord.
12. Reconnect/Turn on the 12 VDC power.
13. Check LP gas safety shutoff.

REFRIGERATOR REMOVAL

- i** Refrigerator removal and installation should be performed by a qualified service technician.

Before removing the refrigerator:

1. Verify that the 120 VAC power cord is disconnected at the rear of the refrigerator.
2. Verify that the 12 VDC leads are disconnected and capped at the rear of the refrigerator.
3. Shut off the gas supply.
4. Disconnect and cap the LP gas line at rear of refrigerator.

NOTICE

Always use a backup wrench when loosening and tightening LP gas connections.

To remove the refrigerator:

1. Remove the screws anchoring the refrigerator to the enclosure.
2. Slide the refrigerator out of the compartment.

To replace the refrigerator:

1. Make sure the sealing strips (isolating the appliance combustion system from the vehicle interior) are properly positioned for a complete seal.
2. Slide the refrigerator back into the compartment.
3. Replace the screws anchoring the refrigerator to the enclosure.
4. Reconnect the LP gas supply line at the rear of the refrigerator.

NOTICE

Always use a backup wrench when loosening and tightening LP gas connections.

5. Check all connections for LP gas leaks.
6. Reconnect the 12 VDC leads at rear of refrigerator.
7. Reconnect the 120 VAC power cord at rear of refrigerator.

TROUBLESHOOTING

If you run into a problem, refer to the troubleshooting table below.

Symptom	Check/Remedial action
Refrigerator stops cooling.	<ul style="list-style-type: none"> • Immediately turn the refrigerator off and contact a Dometic dealer or Service Center. NOTE! Do not leave it running for an extended period of time, and never try to solve the problem by repeatedly restarting the refrigerator. • Do not use the refrigerator until it has been repaired
Refrigerator emits an ammonia smell	<ul style="list-style-type: none"> • Immediately turn the refrigerator off at the front control panel. • Do NOT open refrigerator doors. • Open coach windows and doors (to air out the coach) and evacuate. • Turn off manual LP gas valve at rear of refrigerator. • Disconnect the 120 VAC power at rear of refrigerator. • Contact a Dometic dealer or Service Center for repair. • Do not use the refrigerator until it has been repaired.
Refrigerator or freezer is not cold enough	<ul style="list-style-type: none"> • For refrigerators equipped with a thermostat, check the thermostat and adjust if necessary. • Is the plug firmly connected to the socket? Is the socket switched on? Check the socket by plugging in another appliance. • Is the refrigerator level? (Due to the nature of its operation it is important to keep an absorption refrigerator level.) • Door closing properly? Check the door gasket. • Heavy frost build-up on evaporator fins? To prevent frost build-up do not leave the unit's door open longer than necessary. • Over packed refrigerator? The unit will have to work harder if the refrigerator is stuffed, and results in higher cabinet temperatures. Arrange the food in the unit to allow for free air circulation.
Refrigerator does not work on electric	<ul style="list-style-type: none"> • Is the plug firmly connected to the receptacle? Is the receptacle energized? Check the receptacle by plugging in another appliance. • Is there a power failure? • Blown fuse. Turn refrigerator off and contact a Dometic dealer or Service Center for repair.
The refrigerator does not work in gas operation mode	<ul style="list-style-type: none"> • LP gas bottle empty? Change the gas bottle. • Air in the gas line? Remove the air by repeating the ignition sequence. • If problem resists, turn refrigerator off and contact a Dometic dealer or Service Center for repair.
Refrigerator emits an odor from fumes:	<ul style="list-style-type: none"> • Dislocated or damaged burner. Turn refrigerator off and contact a Dometic dealer or Service Center for repair. • Dirty flue tube. Turn refrigerator off and contact a Dometic dealer or Service Center for repair.

If the problem persists and the refrigerator is still not working properly, turn refrigerator off and contact your nearest Service Center. State the problem, model, product, and serial number. These details are stated on the data label inside the refrigerator compartment.

APPENDIX A - SPARE PARTS

MODEL	RM2351	RM2354	RM2451	RM2454	RM2551	RM2554	DM2652
SPARE PARTS							
Airing position card	N/A	N/A	N/A	N/A	N/A	N/A	3312986.403
Baffle	2007172022	2007172022	2932667013	2932667013	2932667021	2932667021	2932667039
Box	2932636018	2932636018	N/A	N/A	N/A	N/A	N/A
Box, vegetable	N/A	N/A	N/A	N/A	2932621010	2932621010	2932621010
Box, vegetable (crisper), 2 pieces	N/A	N/A	N/A	N/A	N/A	N/A	N/A
Box, vegetable (meat locker)	N/A	N/A	N/A	N/A	N/A	N/A	N/A
Burner (with conductor)	2930697079	2930697079	2930697079	2930697079	2930697079	2930697079	2930697079
Door reversing kit, (light brown)	385030401	385030401	N/A	N/A	N/A	N/A	N/A
Door reversing kit, (black)	385030402	385030402	N/A	N/A	N/A	N/A	N/A
Door reversing kit, right-left (light brown)	N/A	N/A	293275002	293275002	293275002	293275002	293275008
Door reversing kit, left-right (light brown)	N/A	N/A	293275003	293275003	293275003	293275003	293275009
Door reversing kit, right-left (black)	N/A	N/A	293275013	293275013	293275013	293275013	293275011
Door reversing kit, left-right (black)	N/A	N/A	293275014	293275014	293275014	293275014	293275012
Door shelf, lower	N/A	N/A	2932575018	2932575018	2932575018	2932575018	2932575018
Door shelf, (2 pieces)	N/A	N/A	2932576016	2932576016	N/A	N/A	2932576016
Door shelf, (3 pieces)	2002261242	2002261242	N/A	N/A	2932576016	2932576016	N/A
Door shelf, freezer	N/A	N/A	N/A	N/A	N/A	N/A	2932577014
Electrode	2932781012	2932781012	2932781012	2932781012	2932781012	2932781012	2932781012
Halogen lamp (12V, 10W base G4)	N/A	N/A	N/A	N/A	N/A	N/A	N/A
Handle (black)	N/A	N/A	2932670025	2932670025	2932670025	2932670025	3851174023
Heater 175W, 12V	N/A	3850646104	N/A	3850646104	N/A	3850646104	N/A
Heater 175W, 120V	3850644455	3850644455	3850644455	3850644455	3850644455	3850644455	N/A
Heater 275W, 12V	N/A	N/A	N/A	N/A	N/A	N/A	N/A
Heater 325W, 120V	N/A	N/A	N/A	N/A	N/A	N/A	3850644422

APPENDIX A - SPARE PARTS

MODEL	DM2662	DM2663	DM2852	DM2862	NDM1062
SPARE PARTS					
Airing position card	3312986.403	3312986.403	3312986.403	3312986.403	N/A
Baffle	2932667039	2932667039	2932667047	2932667047	2932667047
Box	N/A	N/A	N/A	N/A	N/A
Box, vegetable	2932621077	2932621077	2932621010	2932621077	N/A
Box, vegetable (crisper), 2 pieces	N/A	N/A	N/A	N/A	2002726178
Box, vegetable (meat locker)	N/A	N/A	N/A	N/A	2932621085
Burner (with conductor)	2930697079	2930697079	2930697079	2930697079	2930697079
Door reversing kit, (light brown)	N/A	N/A	N/A	N/A	N/A
Door reversing kit, (black)	N/A	N/A	N/A	N/A	N/A
Door reversing kit, right-left (light brown)	N/A	N/A	293275008	N/A	N/A
Door reversing kit, left-right (light brown)	N/A	N/A	293275009	N/A	N/A
Door reversing kit, right-left (black)	293275011	293275011	293275011	293275011	293275011
Door reversing kit, left-right (black)	293275012	293275012	293275012	293275012	293275012
Door shelf, lower	2932575059	2932575059	2932575018	2932575059	2932575075
Door shelf, (2 pieces)	2932576065	2932576065	N/A	N/A	N/A
Door shelf, (3 pieces)	N/A	N/A	2932576016	2932576065	2932576081
Door shelf, freezer	N/A	N/A	2932577014	N/A	N/A
Electrode	2932781012	2932781012	2932781012	2932781012	2932781012
Halogen lamp (12V, 10W base G4)	N/A	N/A	N/A	N/A	3850455019
Handle (black)	3851174023	3851174023	3851174023	3851174023	2932094044
Heater 175W, 12V	N/A	N/A	N/A	N/A	N/A
Heater 175W, 120V	N/A	N/A	N/A	N/A	N/A
Heater 275W, 12V	N/A	3850646096	N/A	N/A	N/A
Heater 325W, 120V	3850644422	3850644422	3850644422	3850644422	3850644422

APPENDIX B - REARVIEW EQUIPMENT

RM2351 & RM2354

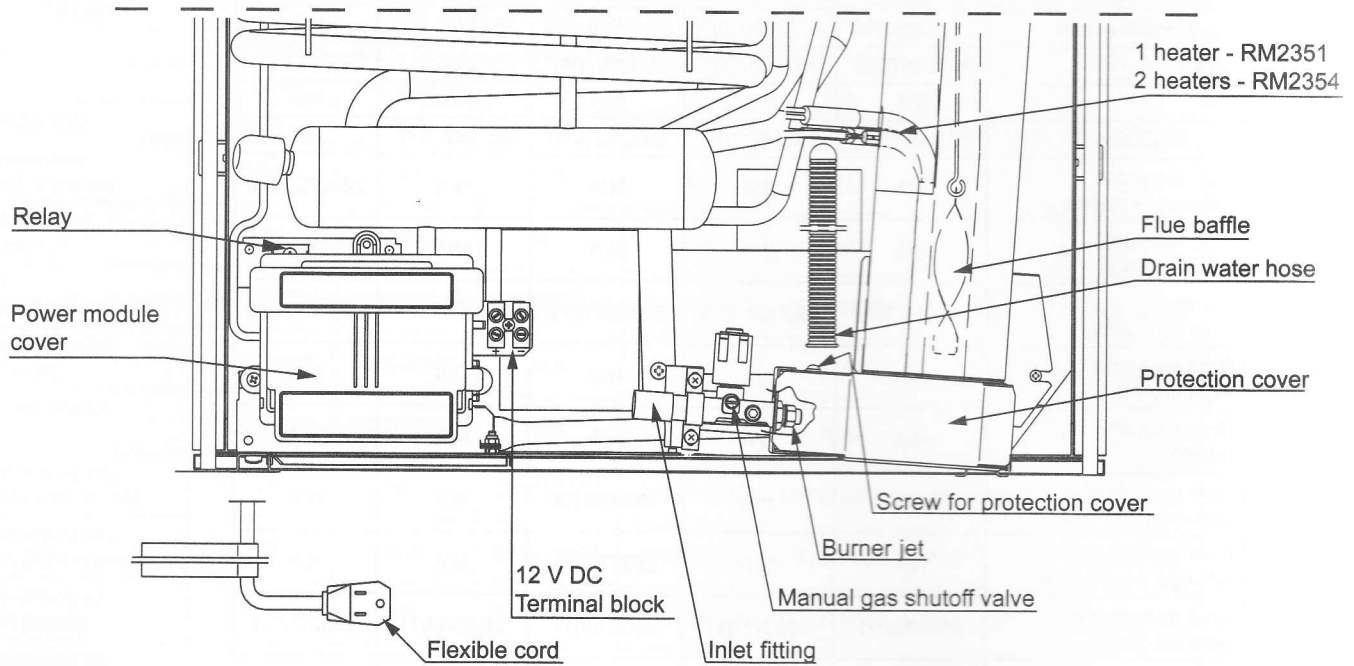

RM2451, RM2454, RM2551 & RM2554

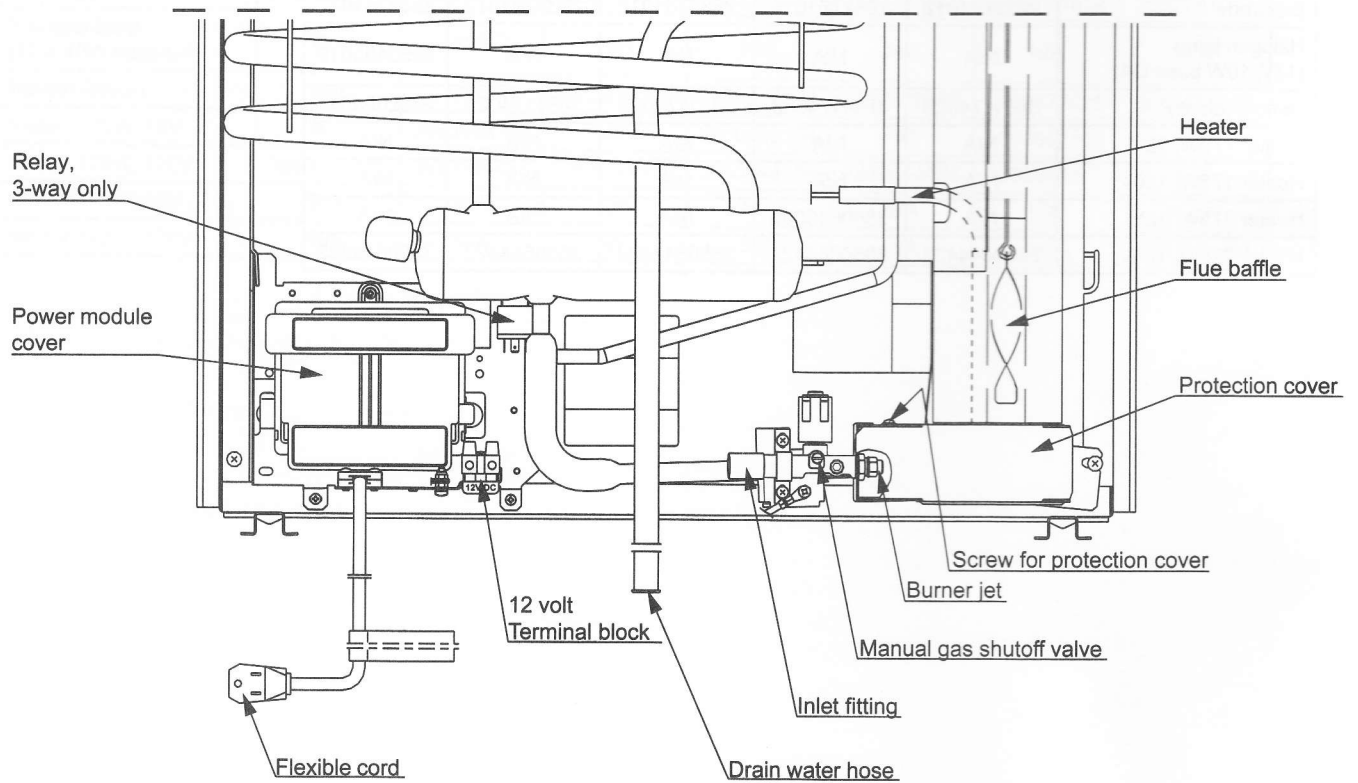

APPENDIX B - REARVIEW EQUIPMENT

DM2652, DM2662, DM2663, DM2852, DM2862 & NDM1062

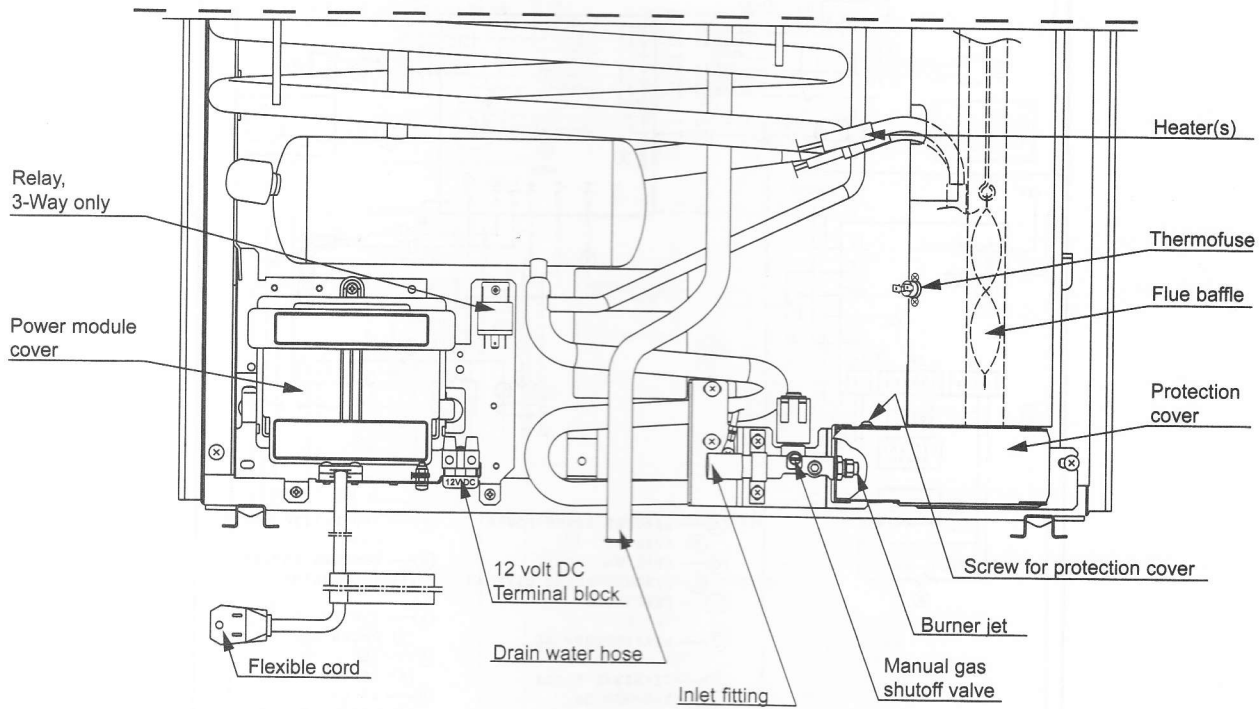

Shown without Secondary Burner Housing for illustrative purposes only.

NDM1062 (WITH ICE MAKER)

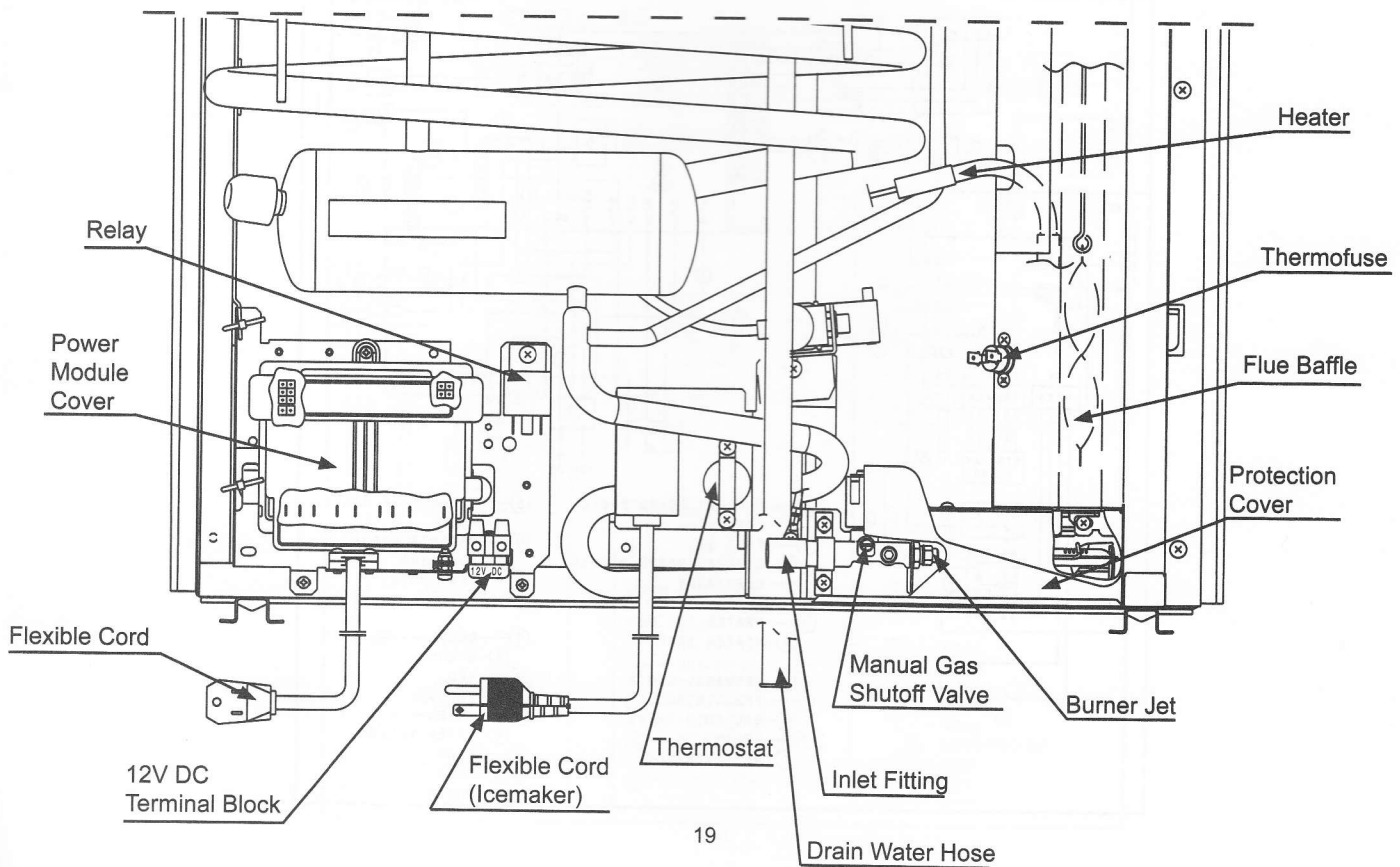

Shown without Secondary Burner Housing for illustrative purposes only.

APPENDIX C - WIRING DIAGRAM

RM2351, RM2451 & RM2551

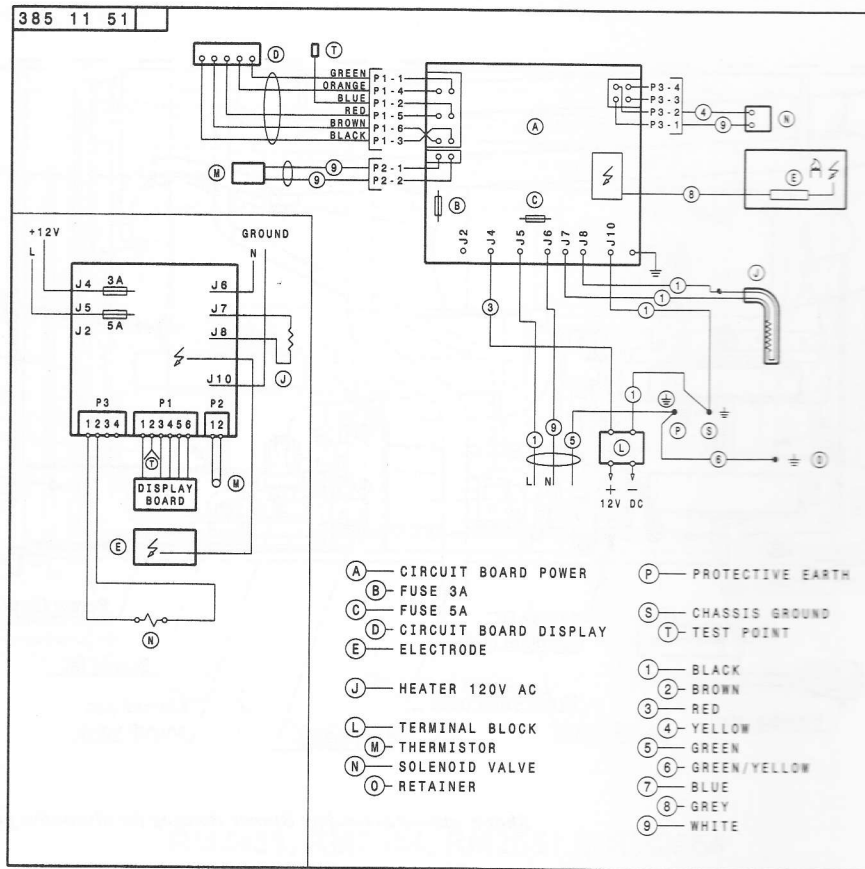

RM2354, RM2454 & RM2554

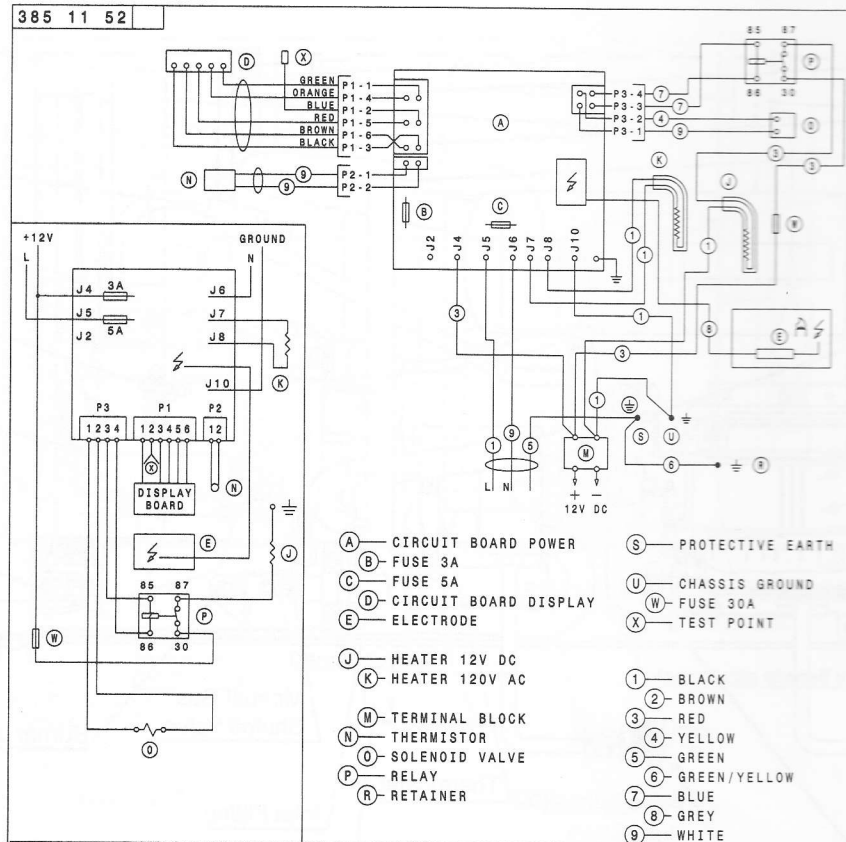

APPENDIX C - WIRING DIAGRAM

DM2652, DM2662, DM2852 & DM2862

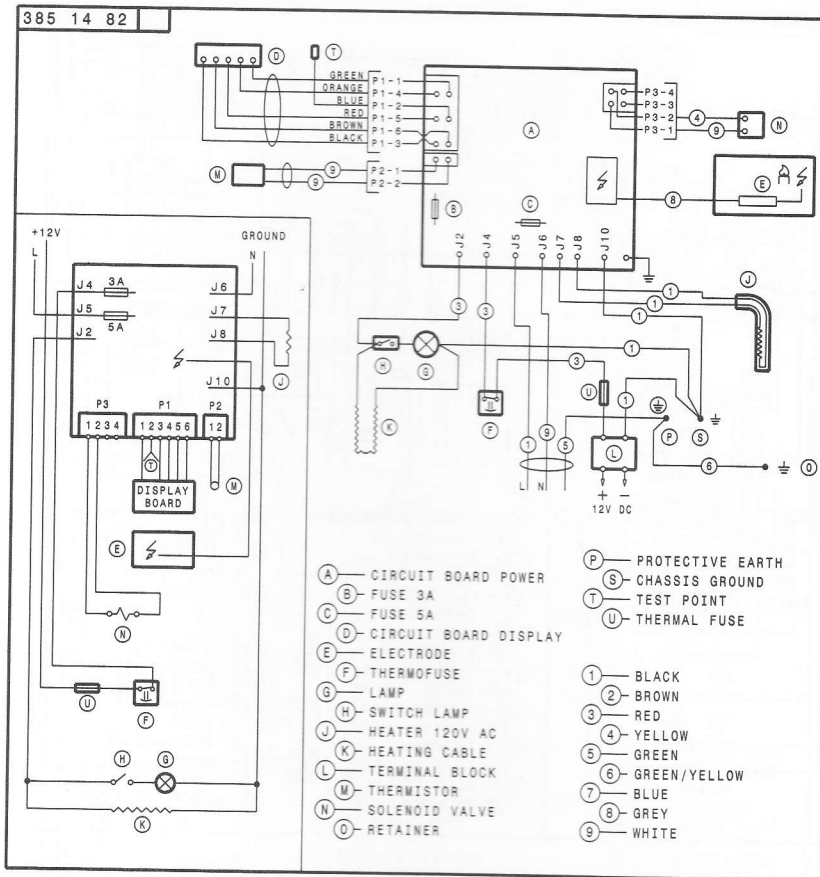

DM2652, DM2852 & DM2862 (WITH OPTIONAL FAN)

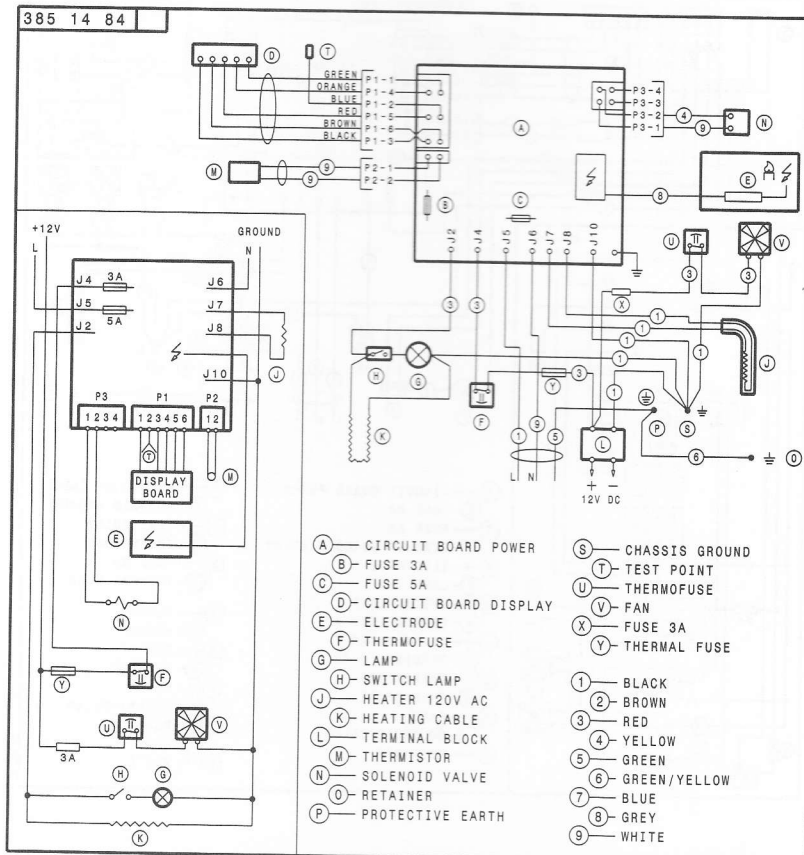

APPENDIX C - WIRING DIAGRAM

DM2663

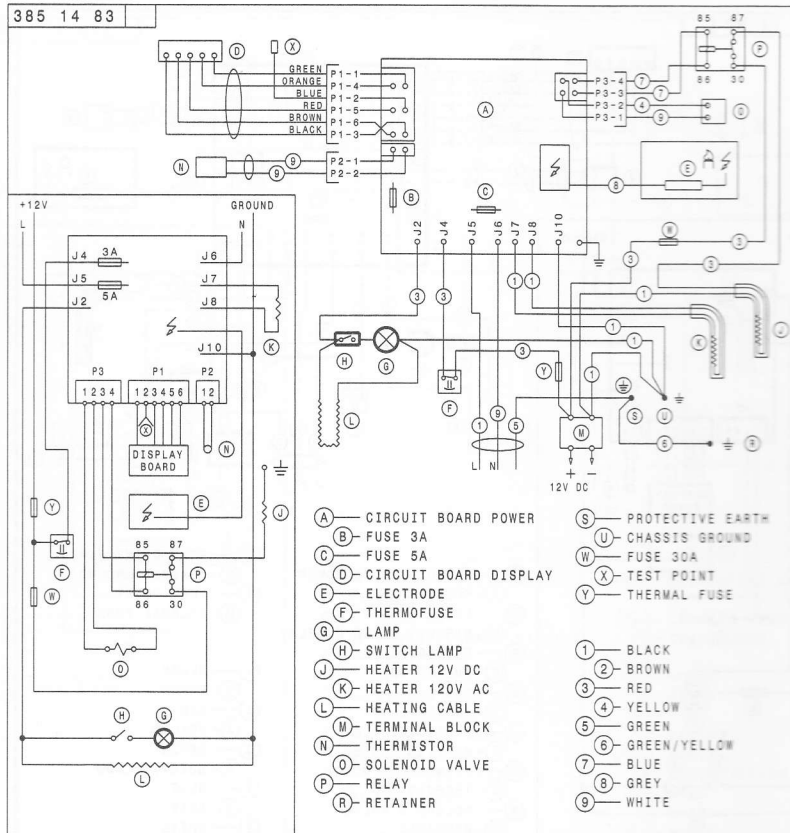

NDM1062 (STAINLESS STEEL DOORS)

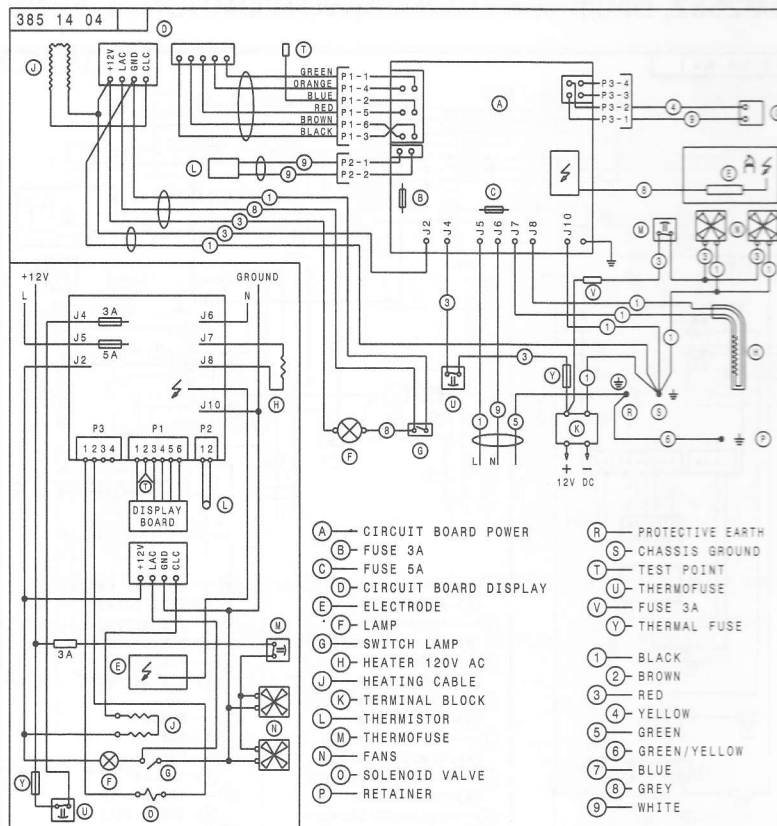

APPENDIX C - WIRING DIAGRAM

NDM1062 (STAINLESS STEEL DOORS & ICE MAKER)

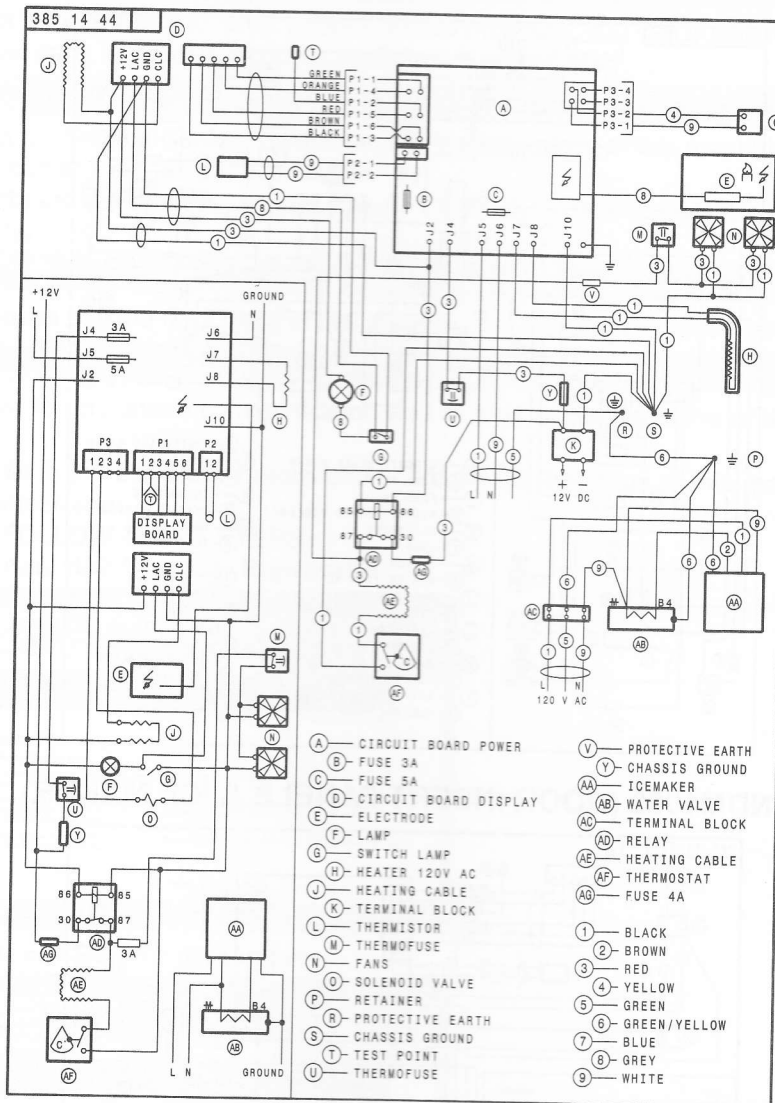

APPENDIX C - WIRING DIAGRAM

NDM1062 (DOOR INSERT PANELS)

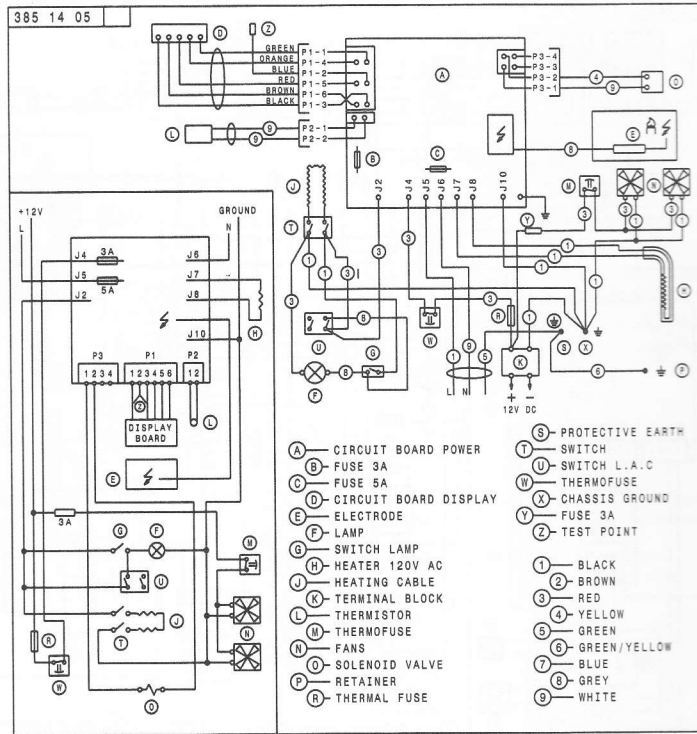

NDM1062 (DOOR INSERT PANELS & ICE MAKER)

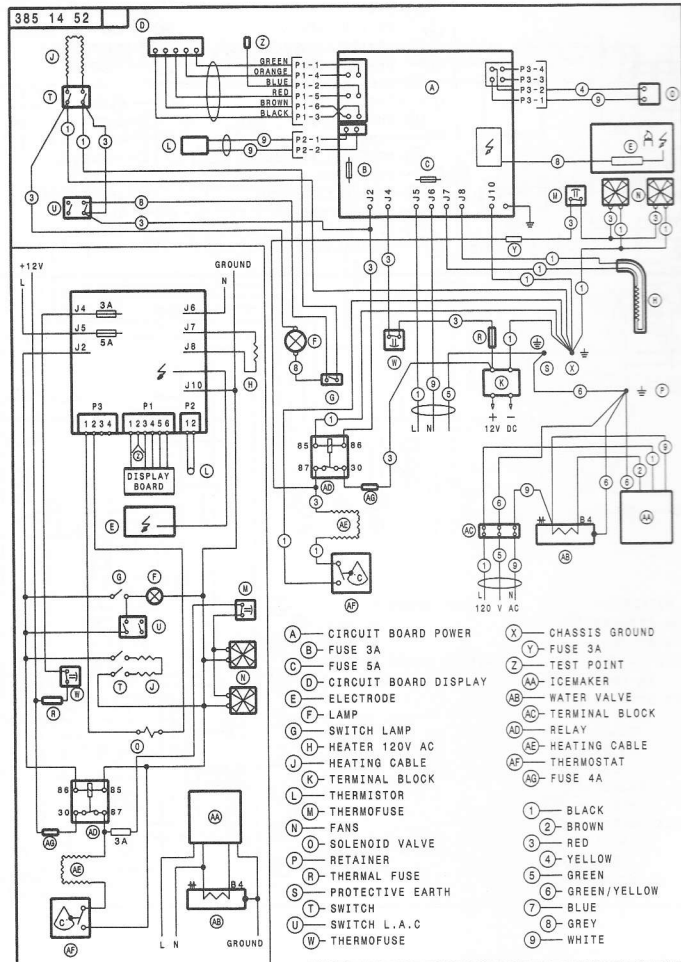

APPENDIX D - CONSUMER SUPPORT

Dometic website

www.dometicusa.com

Please visit the website for information and news about Dometic products. You can obtain information about how to get in contact, learn about product care, download manuals, leaflets and warranties.

Service and spare parts

For service, please contact the Service Center Assistance, see the front page of this manual - or - visit the Dometic website to find the location of the nearest Dometic Service Center.

Commonly used spare parts are listed in this manual, see APPENDIX A - SPARE PARTS. These should be available from your Dometic Service Center.

Contact us

For contact information, please see the front page of this manual - or - visit the Dometic website.

Register the appliance

www.edometic.com

Timely registration will allow for enhanced communication and service under the terms of the warranty, see Appendix E - Dometic warranty.

To register the appliance, fill in the pre-printed registration card on the last page of this manual or register on-line at the Dometic website www.edometic.com.

TO REGISTER ON-LINE, FOLLOW THESE STEPS:

1. At www.edometic.com, click Warranty Registration.

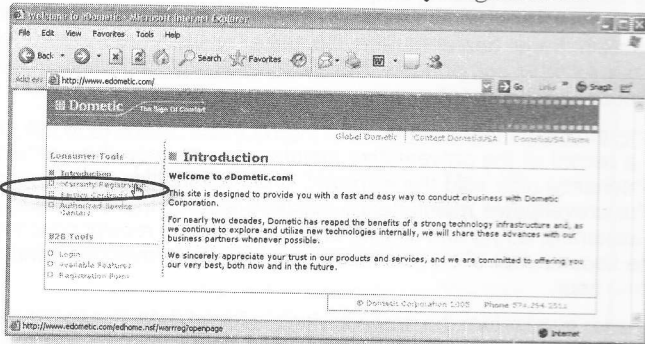

2. Click Register your new Dometic product here.

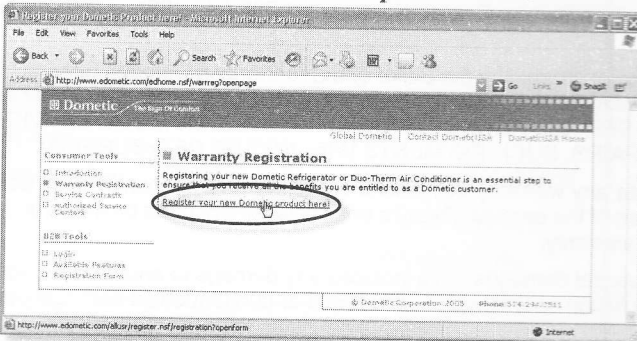

3. Complete the information and then, click the Submit Registration button.

A screenshot of the "Dometic Owner's Registration" form. The form includes fields for "First", "Last", "Street", "City", "State/Prov.", "Zip", "Canadian Zip", "Model Number", "Serial Number", and "Date of Purchase". There are also fields for "E-Mail Address", "Home Phone", and "Work Phone". A "SUBMIT Registration" button is at the bottom left.

A close-up of a data label from a refrigerator compartment. The label contains the following information:

MOD. NO.	INPUT RATE	REFRIG. (R)
PRD. NO.		
SER. NO.	EQUIPPED FOR LP GAS	
	MAXIMUM PRESSURE OF 11" P.S.I.	
120V 60HZ	AMP	REFRIGERANT 717 oz.
12V	AMP	Refr. Co. =

Additional text on the label includes: "FOR MANUFACTURED HOME (MOBILE HOMES) OR RECREATIONAL VEHICLE INSTALLATION", "FOR INSTALLATION DANS UNE MAISON PREFABRIQUEE (MOBILES) OU UN VEHICULE DE CAMPING", "TESTED TO ISO 13716 * (5.06 MPa)", "INSTALL ONLY WITH VENT KIT ACCORDING TO FORM NO. 310 99 37...", "INSTALLER UNIQUEMENT AVEC LA TROUSSE D'AIR DE COMBUSTION CONFORME/MENT FORMULETIE NO. 310 99 37...", and "3092720-00 MADE IN SWEDEN".

The model number (e.g. DM2662) and serial number (e.g. 012 34567) are stated on the data label in the refrigerator compartment.

APPENDIX E - DOMETIC WARRANTY

Congratulations, and Thank You for purchasing the industry's best built and best backed RV Refrigerator. Below you will find important warranty and maintenance information on Dometic's exclusive two (2) year warranty. Please take a few moments and familiarize yourself with the program. We at Dometic appreciate your business and are confident that you will have many years of trouble-free RV enjoyment.

LIMITED TWO-YEAR WARRANTY DOMETIC REFRIGERATORS THE SELLER NAMED BELOW MAKES THE FOLLOWING WARRANTY WITH RESPECT TO THE DOMETIC PRODUCT:

1. This warranty is made only to the first purchaser (herein after referred to as the "Original Purchaser") who acquires the product for his own use and is installed and operated within the continental United States and Canada.
2. This warranty will be in effect for two years on parts and freight and two years on labor from the date of purchase by the Original Purchaser. It is suggested that the original purchaser retain a copy of the dated bill of sale as evidence of the date of purchase.
3. This warranty covers only specified parts, which shall be free from defects in material and workmanship under normal use. This warranty does not cover conditions unrelated to the material and workmanship of the product. Such unrelated conditions include, but are not limited to: (a) damage not reported within the first 7 days of ownership; (b) faulty installation or installation that does not comply with RVIA standards, and any damage resulting from such; (c) the need for normal maintenance and any damage resulting from the failure to provide such maintenance; (d) failure to follow Sellers instructions for use of product; (e) any accident to or misuse of any part of this product and any alteration by anyone other than the Seller or its authorized representative; (f) any non-Dometic parts that are installed as replacement parts will void any warranty (implied or written); (g) blow out conditions; (h) radio frequency interference and electromagnetic interference; (i) 12V system chassis ground decay and corrosion; (j) puncture of foam cabinet or vacuum insulated panels after acknowledged receipt; (k) animal or insect infiltration which damages unit or inhibits performance; (l) abuse or misuse of electrical components.
4. The specified parts covered by this warranty are as follows: Major components (cooling unit, LP gas valve, burner, burner housing, electronic display, electronic module, evaporator fins, foam integrity, frame, thermistor, spark probe, ignition wire, ice maker compressor, second absorption loop, display escutcheon, lower toe plate, humidity switch, frame heater mullion, ice maker mullion) are covered for parts and freight for two years and labor for two years from date of purchase. All other components that fail must be reported within the first 90 days of ownership in order to receive coverage of parts, freight and labor under warranty.
5. **This warranty requires the Original Purchaser to provide preventative maintenance on a yearly basis, starting at the anniversary of his date of purchase.** The Original Purchaser must keep a record of the preventative maintenance to keep the warranty in effect. Failure of the Original Purchaser in providing this annual maintenance may void the warranty. The preventative maintenance must be performed at a Dometic Authorized Service Center/Dealer. The preventative maintenance required is an inspection, cleaning and full diagnostics performed on the entire electronic system, burner assembly, wiring and cooling unit. A copy of the receipt covering the maintenance checks must accompany the warranty claim during the second year of ownership. The cost of this preventative maintenance is the Original Purchaser's responsibility and should take about one hour.
6. In order to obtain the benefits of this warranty, the original purchaser must return the product which is found defective to the Seller named below or to a Dometic Authorized Service Center during the period that this warranty is in effect. The original purchaser is responsible for all charges incurred in delivery of the product to the Seller or Dometic Authorized Service Center, and in pick up after the warranty service has been completed. To obtain the location of the nearest Authorized Service Center, please call 1-800-544-4881 or in Canada call 1-519-653-4390.
7. Any item returned in the manner described in paragraph 6 will be examined by the Seller or the Authorized Dometic Service Center. If it is found that the returned item was defective in material and workmanship, the Seller or the Authorized Dometic Service Center will repair the product per the terms outlined in paragraph 4. **CONFIRM THE SERVICE AGENCY IS AN AUTHORIZED DOMETIC SERVICE CENTER. DO NOT PAY THE SERVICE AGENCY FOR WARRANTY REPAIRS. SUCH PAYMENTS WILL NOT BE REIMBURSED.**
8. The Seller does not authorize any person or company to create any warranty obligations or liability on their behalf. This warranty is not extended by the length of time which you are deprived of the use of the product. Repairs and replacement parts provided under the terms of this warranty shall carry only the non-expired portion of this warranty.
9. In no event shall either seller be liable for incidental or consequential damages. This includes any damage to another product or products resulting from such a defect. Some states do not allow the exclusion or limitation of incidental or consequential damages, so the above limitations may not apply.
10. Any implied warranty, including the implied warranty of merchantability and fitness for any purpose, is limited to the duration of this limited warranty. Some states do not allow limitations on how long an implied warranty can last, so the above limitation may not apply.
11. **THIS WARRANTY GIVE SPECIFIC LEGAL RIGHTS, YOU MAY ALSO HAVE OTHER RIGHTS WHICH VARY FROM STATE TO STATE.** No action to enforce this warranty shall be commenced later than ninety (90) days after the expiration of the warranty period. Claims must be submitted in writing to the Dometic Warranty Department for arbitration.
12. All products (except those specifically built for commercial use) are warranted only when installed in vehicles built to current edition R.V.I.A A119.2 and C.R.V.A. Z-240 Standards.
13. The Seller reserves the right to change the design of any product without notice and with no obligation to make corresponding changes in products previously manufactured.

DOMETIC, LLC
Warranty Department
2320 Industrial Parkway
Elkhart, IN 46516
Phone: 574-294-2511
Fax: 574-389-3975

APPENDIX F - MAINTENANCE SCHEDULE

REFRIGERATOR OWNER MAINTENANCE YEARLY RECORD

Customer Name: _____ Model No.: _____ Date of Purchase: _____
 Address: _____ Serial No.: _____
 City: _____ State: _____ Zip Code: _____
 Phone: _____

FIRST YEAR

Date: _____
 Dealership: _____
 Address: _____
 City: _____
 State: _____ Zip: _____
 Phone: _____
 Technician: _____

SECOND YEAR

Date: _____
 Dealership: _____
 Address: _____
 City: _____
 State: _____ Zip: _____
 Phone: _____
 Technician: _____

Cleaned Burner Assembly: Yes / No
 Cleaned/Check All Terminals Connections: Yes / No
 Cleaned/Inspect All Ground Connections: Yes / No
 Inspect and Test Door Seals: Yes / No
 Inspect and Tighten LP Lines: Yes / No
 Power Ventilator Installed: Yes / No
 *Gas Safety Shutdown in 45 seconds: Yes / No

Cleaned Burner Assembly: Yes / No
 Cleaned/Check All Terminals Connections: Yes / No
 Cleaned/Inspect All Ground Connections: Yes / No
 Inspect and Test Door Seals: Yes / No
 Inspect and Tighten LP Lines: Yes / No
 Power Ventilator Installed: Yes / No
 *Gas Safety Shutdown in 45 seconds: Yes / No

	ACTUAL	SPEC. RANGE
Electrode Gap	_____	3/16"
Thermister Reading	_____	7-10,000 ohms @ 32°
*D/C Voltage	_____	9.5 to 15 volts D/C
*A/C Voltage	_____	120 Volts ± 10%
Thermocouple Reading	_____	25-35 Millivolts
*Delay Between Modes	_____	Approx. 5 seconds

* Use PAL RV Diagnostic Tool for these tests.

	ACTUAL	SPEC. RANGE
Electrode Gap	_____	3/16"
Thermister Reading	_____	7-10,000 ohms @ 32°
*D/C Voltage	_____	9.5 to 15 volts D/C
*A/C Voltage	_____	120 Volts ± 10%
Thermocouple Reading	_____	25-35 Millivolts
*Delay Between Modes	_____	Approx. 5 seconds

* Use PAL RV Diagnostic Tool for these tests.

ICEMAKER MODELS

Inspect Water Valve and All Connections: Yes / No
 Inspect Heat Tape Switch for Proper
 Operation: Yes / No

ICEMAKER MODELS

Inspect Water Valve and All Connections: Yes / No
 Inspect Heat Tape Switch for Proper
 Operation: Yes / No